





US012334631B2

(12) **United States Patent**  
**Tanaka**

(10) **Patent No.:** **US 12,334,631 B2**  
(45) **Date of Patent:** **Jun. 17, 2025**

(54) **COMMUNICATION DEVICE AND ANTENNA-INCORPORATED DEVICE**

(71) Applicant: **CANON KABUSHIKI KAISHA**, Tokyo (JP)

(72) Inventor: **Yu Tanaka**, Tokyo (JP)

(73) Assignee: **Canon Kabushiki Kaisha**, Tokyo (JP)

(\* ) Notice: Subject to any disclaimer, the term of this patent is extended or adjusted under 35 U.S.C. 154(b) by 225 days.

(21) Appl. No.: **18/324,033**

(22) Filed: **May 25, 2023**

(65) **Prior Publication Data**  
US 2023/0387581 A1 Nov. 30, 2023

(30) **Foreign Application Priority Data**  
May 26, 2022 (JP) ..... 2022-086232

(51) **Int. Cl.**  
**H01Q 1/42** (2006.01)  
**H01Q 1/24** (2006.01)  
**H01Q 9/16** (2006.01)

(52) **U.S. Cl.**  
CPC ..... **H01Q 1/42** (2013.01); **H01Q 9/16** (2013.01)

(58) **Field of Classification Search**  
CPC ..... H01Q 1/24; H01Q 1/245; H01Q 1/42; H01Q 5/321; H01Q 5/371; H01Q 9/065; H01Q 9/285; H01Q 9/16; H01Q 9/30; H01Q 21/29  
See application file for complete search history.

(56) **References Cited**  
  
FOREIGN PATENT DOCUMENTS  
JP 2003110329 A 4/2003  
JP 2012231266 A \* 11/2012 ..... H01Q 1/526  
\* cited by examiner

*Primary Examiner* — Hoang V Nguyen  
(74) *Attorney, Agent, or Firm* — Canon U.S.A., Inc. IP Division

(57) **ABSTRACT**  
A communication device includes a conductive housing and an antenna device arranged in the housing. The housing includes a first plane and a second plane facing the first plane, and a conductor of the first plane is provided with at least one aperture. The antenna device includes a first element including a first terminal and extending in a direction intersecting the first plane. The antenna device includes a second element including a first end, connected to the first element, and extending along the first plane. The first and second elements are overlapping the aperture in a direction vertical to the first plane, and a shortest distance from the first end of the second element to an end portion of the aperture is longer than a shortest distance from the first terminal of the first element to another end portion of the aperture in a direction vertical to the first plane.

**11 Claims, 10 Drawing Sheets**

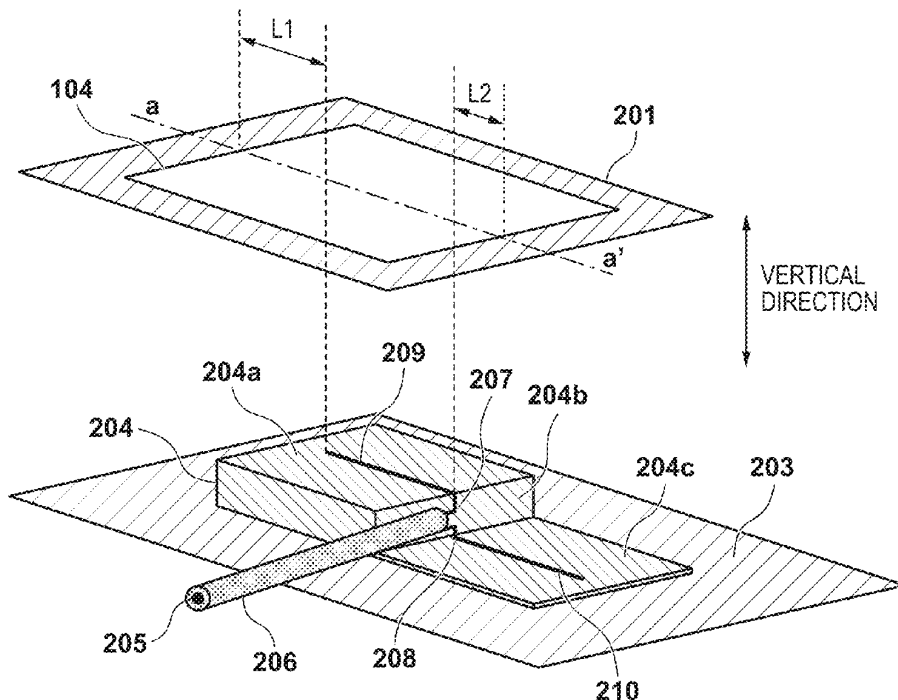



US012334633B2

(12) **United States Patent**  
**Smith et al.**

(10) **Patent No.:** **US 12,334,633 B2**  
(45) **Date of Patent:** **Jun. 17, 2025**

(54) **COAXIAL STRUCTURE FOR ENABLING ELECTROMAGNETIC COMMUNICATIONS BETWEEN A CIRCUIT BOARD AND ANTENNA ARRAY**

(58) **Field of Classification Search**  
CPC ..... H01Q 1/50; H01R 12/714; H01R 13/24; H01R 43/16; H01R 2201/02; H01R 13/2492; H01R 24/50  
See application file for complete search history.

(71) Applicant: **Optisys, Inc.**, Salt Lake City, UT (US)

(56) **References Cited**

(72) Inventors: **Robert Smith**, Salt Lake City, UT (US); **Gregory Dunstan**, Salt Lake City, UT (US)

U.S. PATENT DOCUMENTS

(73) Assignee: **Optisys, Inc.**, Salt Lake City, UT (US)

(\* ) Notice: Subject to any disclaimer, the term of this patent is extended or adjusted under 35 U.S.C. 154(b) by 252 days.

5,380,211 A \* 1/1995 Kawaguchi ..... H01R 24/50 439/700  
7,118,383 B2 \* 10/2006 Nagata ..... H01R 12/52 439/63  
9,525,220 B1 \* 12/2016 Burris ..... H01R 13/6593

FOREIGN PATENT DOCUMENTS

(21) Appl. No.: **18/304,293**

EP 4047748 B1 \* 12/2024 ..... H01Q 1/1207

(22) Filed: **Apr. 20, 2023**

\* cited by examiner

(65) **Prior Publication Data**

US 2023/0387586 A1 Nov. 30, 2023

*Primary Examiner* — Seung H Lee

(74) *Attorney, Agent, or Firm* — TechLaw Ventures, PLLC; Terrence J. Edwards

**Related U.S. Application Data**

(60) Provisional application No. 63/363,304, filed on Apr. 20, 2022.

(57) **ABSTRACT**

Electrical connectors and means for facilitating electromagnetic communication between an antenna array and a circuit board. A system includes a circuit board comprising an electrically conductive pad, a coaxial pin, and a spring pin configured to be disposed around at least a portion of the coaxial pin. The spring pin enables the coaxial pin to maintain an electrical connection with the electrically conductive pad of the circuit board.

(51) **Int. Cl.**  
**H01Q 1/50** (2006.01)  
**H01R 12/71** (2011.01)  
**H01R 13/24** (2006.01)  
**H01R 43/16** (2006.01)

(52) **U.S. Cl.**  
CPC ..... **H01Q 1/50** (2013.01); **H01R 12/714** (2013.01); **H01R 13/24** (2013.01); **H01R 43/16** (2013.01); **H01R 2201/02** (2013.01)

**20 Claims, 9 Drawing Sheets**

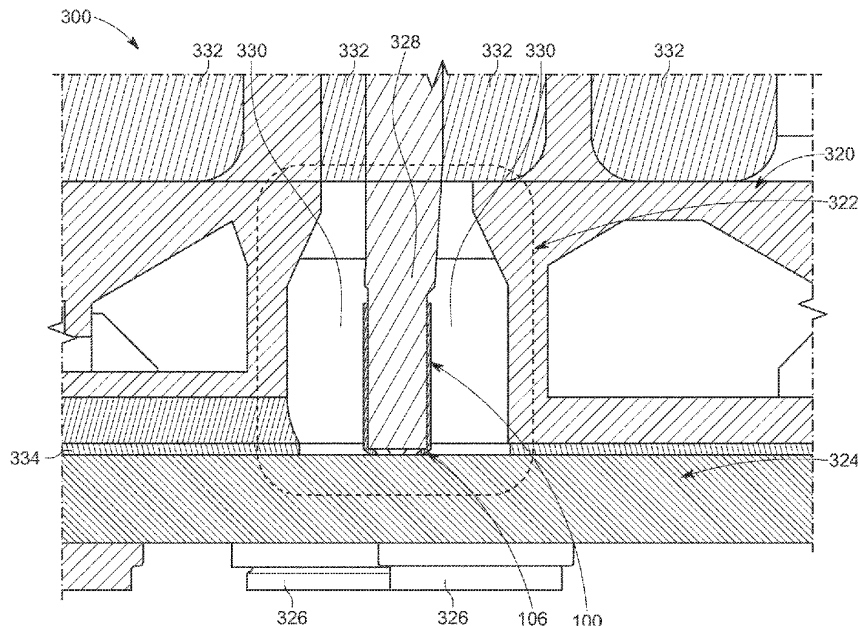



US012334637B2

(12) **United States Patent**  
**Cheah et al.**

(10) **Patent No.:** **US 12,334,637 B2**  
(45) **Date of Patent:** **Jun. 17, 2025**

- (54) **METASURFACE ANTENNA**
- (71) Applicants: **Tyco Electronics Holdings (Bermuda) No. 7 Limited**, Taipei (TW); **Tyco Electronics Singapore Pte Ltd.**, Singapore (SG); **National University of Singapore**, Singapore (SG)
- (72) Inventors: **Sin-Hooi Cheah**, Taipei (TW); **Kim Hai Wong**, Singapore (SG); **Wei Liu**, Singapore (SG); **Zhining Chen**, Singapore (SG)
- (73) Assignees: **Tyco Electronics Holdings (Bermuda) No. 7 Limited**, Taipei (TV); **Tyco Electronics Singapore Pte Ltd.**, Singapore (SG); **National University of Singapore**, Singapore (SG)

- (56) **References Cited**
- U.S. PATENT DOCUMENTS
- 2012/0287008 A1 \* 11/2012 Kim ..... H01Q 1/52 343/841
- 2020/0227821 A1 \* 7/2020 Wu ..... H01Q 1/38
- FOREIGN PATENT DOCUMENTS
- CN 204011989 U 12/2014
- CN 107123898 A 9/2017
- (Continued)
- OTHER PUBLICATIONS
- Extended European Search Report for corresponding EP Application No. 23160207.9-1205 dated Oct. 23, 2023 (15 pages).
- (Continued)

(\*) Notice: Subject to any disclaimer, the term of this patent is extended or adjusted under 35 U.S.C. 154(b) by 413 days.

*Primary Examiner* — Dieu Hien T Duong  
(74) *Attorney, Agent, or Firm* — Jay J. Hoette; The Small Patent Law Group, LLC

- (21) Appl. No.: **17/687,855**
  - (22) Filed: **Mar. 7, 2022**
  - (65) **Prior Publication Data**
  - US 2023/0282984 A1 Sep. 7, 2023
  - (51) **Int. Cl.**
  - H01Q 15/00** (2006.01)
  - H01Q 9/04** (2006.01)
  - H01Q 21/06** (2006.01)
  - (52) **U.S. Cl.**
  - CPC ..... **H01Q 15/0086** (2013.01); **H01Q 9/0407** (2013.01); **H01Q 21/065** (2013.01)
  - (58) **Field of Classification Search**
  - CPC ..... H01Q 15/0086; H01Q 9/0407; H01Q 21/065; H01Q 1/523; H01Q 21/0075; H01Q 21/24; H01Q 1/38
- See application file for complete search history.

- (57) **ABSTRACT**
  - An antenna assembly includes a metasurface antenna unit including a radiating structure, a feeding structure, and a grounding structure therebetween. The radiating structure includes radiating elements arranged in an m×n grid of m rows of radiating elements and n columns of radiating elements, where n is greater than m. The radiating elements are separated by radiating slots with edges of the radiating elements facing each other across the radiating slots. The grounding structure includes a ground plane having a coupling aperture therethrough. The feeding structure includes a single strip feedline for feeding the radiating elements. The strip feedline passes across the coupling aperture and feeds the radiating structure through the coupling aperture. At least one of the radiating elements is fed through at least one other radiating element across the corresponding radiating slot.
- 26 Claims, 11 Drawing Sheets**

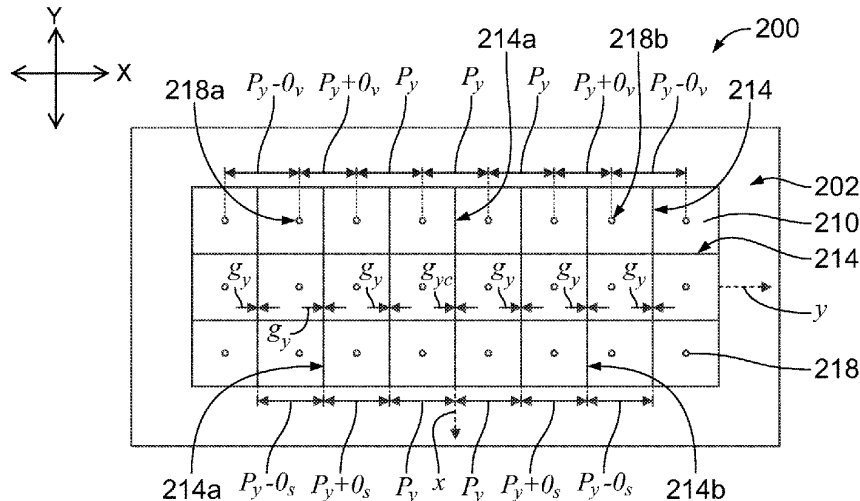



US012334641B2

(12) **United States Patent**  
**Lee et al.**

(10) **Patent No.:** **US 12,334,641 B2**  
(45) **Date of Patent:** **Jun. 17, 2025**

(54) **ANTENNA STRUCTURE AND ELECTRONIC DEVICE INCLUDING THE SAME**

(71) Applicant: **SAMSUNG ELECTRONICS CO., LTD.**, Suwon-si (KR)

(72) Inventors: **Seokmin Lee**, Suwon-si (KR); **Junsig Kum**, Suwon-si (KR); **Yoonjeon Kim**, Suwon-si (KR); **Seungho Choi**, Suwon-si (KR); **Seungtae Ko**, Suwon-si (KR); **Youngju Lee**, Suwon-si (KR)

(73) Assignee: **Samsung Electronics Co., Ltd.**, Suwon-si (KR)

(\*) Notice: Subject to any disclaimer, the term of this patent is extended or adjusted under 35 U.S.C. 154(b) by 81 days.

(21) Appl. No.: **18/108,948**

(22) Filed: **Feb. 13, 2023**

(65) **Prior Publication Data**  
US 2023/0187845 A1 Jun. 15, 2023

**Related U.S. Application Data**

(63) Continuation of application No. PCT/KR2022/003795, filed on Mar. 18, 2022.

(30) **Foreign Application Priority Data**

Mar. 19, 2021 (KR) ..... 10-2021-0036259

(51) **Int. Cl.**  
**H01Q 21/06** (2006.01)  
**H01Q 1/24** (2006.01)  
(Continued)

(52) **U.S. Cl.**  
CPC ..... **H01Q 21/065** (2013.01); **H01Q 1/246** (2013.01); **H01Q 1/52** (2013.01); **H01Q 9/045** (2013.01)

(58) **Field of Classification Search**  
CPC ..... H01Q 21/065; H01Q 1/246; H01Q 1/52; H01Q 9/045; H01Q 1/243; H01Q 21/24;  
(Continued)

(56) **References Cited**

U.S. PATENT DOCUMENTS

6,025,554 A \* 2/2000 Macris ..... H10N 10/17  
136/203  
6,144,344 A \* 11/2000 Kim ..... H01Q 21/10  
343/789

(Continued)

FOREIGN PATENT DOCUMENTS

CN 107425275 12/2017  
CN 109103605 12/2018

(Continued)

OTHER PUBLICATIONS

[Online] Park et al., "Analysis of on the Microstrip Patch Antennas with Air Layers in Dielectric Layer", <http://www.dbpia.co.kr/journal/articalDetail?nodeID=NODE00813262>, Proceedings of KIIT Conference, Aug. 2004, pp. 149-153 (5 pages).

(Continued)

*Primary Examiner* — Hai V Tran

*Assistant Examiner* — Jordan E. DeWitt

(74) *Attorney, Agent, or Firm* — Nixon & Vanderhye P.C.

(57) **ABSTRACT**

The disclosure relates to a pre-5<sup>th</sup>-Generation (5G) or 5G communication system to be provided for supporting higher data rates Beyond 4<sup>th</sup>-Generation (4G) communication system such as Long Term Evolution (LTE). According to an embodiment of the disclosure, an antenna structure of a wireless communication system may include: at least one antenna element including at least one antenna, a power divider configured to feed the at least one antenna element, and a substrate, the at least one antenna element and the power divider may be disposed on the substrate, and, the

(Continued)

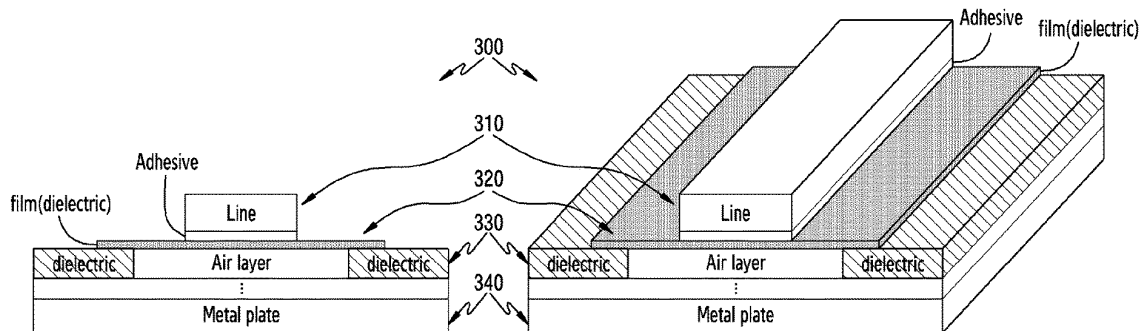



US012334644B2

(12) **United States Patent**  
**Wang**

(10) **Patent No.:** **US 12,334,644 B2**  
(45) **Date of Patent:** **Jun. 17, 2025**

(54) **ANTENNA APPARATUS AND ELECTRONIC DEVICE**

(71) Applicant: **GUANGDONG OPPO MOBILE TELECOMMUNICATIONS CORP., LTD.**, Guangdong (CN)

(72) Inventor: **Zedong Wang**, Guangdong (CN)

(73) Assignee: **GUANGDONG OPPO MOBILE TELECOMMUNICATIONS CORP., LTD.**, Guangdong (CN)

(\*) Notice: Subject to any disclaimer, the term of this patent is extended or adjusted under 35 U.S.C. 154(b) by 247 days.

(21) Appl. No.: **18/341,101**

(22) Filed: **Jun. 26, 2023**

(65) **Prior Publication Data**  
US 2023/0335922 A1 Oct. 19, 2023

**Related U.S. Application Data**  
(63) Continuation of application No. PCT/CN2021/127066, filed on Oct. 28, 2021.

(30) **Foreign Application Priority Data**  
Dec. 28, 2020 (CN) ..... 202011580857.7

(51) **Int. Cl.**  
**H01Q 25/00** (2006.01)  
**H01Q 1/48** (2006.01)

(52) **U.S. Cl.**  
CPC ..... **H01Q 25/00** (2013.01); **H01Q 1/48** (2013.01)

(58) **Field of Classification Search**  
CPC ..... H01Q 25/00; H01Q 1/48  
See application file for complete search history.

(56) **References Cited**

U.S. PATENT DOCUMENTS

2013/0088404 A1 4/2013 Ramachandran et al.  
2017/0048363 A1 2/2017 Lee et al.

FOREIGN PATENT DOCUMENTS

CN 107317095 11/2017  
CN 108321495 7/2018  
CN 108346863 7/2018  
CN 208522084 2/2019  
CN 109921172 6/2019

(Continued)

OTHER PUBLICATIONS

WIPO, International Search Report and Written Opinion for PCT/CN2021/127066, Jan. 19, 2022.

(Continued)

*Primary Examiner* — Henry Luong  
(74) *Attorney, Agent, or Firm* — Hodgson Russ LLP

(57) **ABSTRACT**

Provided are an antenna apparatus and an electronic device. A first coupling gap is formed between one end of a second radiator and a first radiator, and the other end of the second radiator is provided with a first ground terminal. One end of a third radiator is connected to the first ground terminal, and the other end thereof extends in a direction away from the second radiator. The third radiator is provided with a second ground terminal spaced apart from the first ground terminal. At least part of the first radiator and the second radiator jointly generate a first resonance. A part of the third radiator located on a side of the second ground terminal away from the first ground terminal generates a second resonance.

**20 Claims, 7 Drawing Sheets**

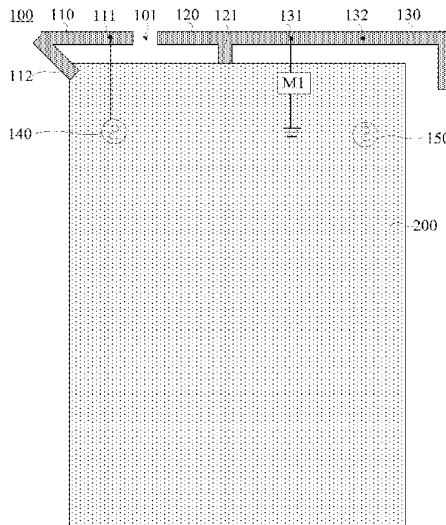



US012334648B2

(12) **United States Patent**  
**Sokolov et al.**

(10) **Patent No.:** **US 12,334,648 B2**  
(45) **Date of Patent:** **Jun. 17, 2025**

(54) **DUAL MODE ANTENNA ARRANGEMENT**

(56) **References Cited**

(71) Applicant: **Huawei Technologies Co., Ltd.**,  
Shenzhen (CN)

U.S. PATENT DOCUMENTS

(72) Inventors: **Konstantin Sokolov**, Helsinki (FI);  
**Hanyang Wang**, Reading (GB);  
**Zlatoljub Milosavljevic**, Helsinki (FI)

7,403,161 B2 7/2008 DiNallo et al.  
7,683,839 B2\* 3/2010 Ollikainen ..... H01Q 9/0421  
343/702

(Continued)

(73) Assignee: **Huawei Technologies Co., Ltd.**,  
Shenzhen (CN)

FOREIGN PATENT DOCUMENTS

(\* ) Notice: Subject to any disclaimer, the term of this  
patent is extended or adjusted under 35  
U.S.C. 154(b) by 97 days.

CN 106252848 B \* 1/2020 ..... H01Q 1/36  
JP 2004088198 A \* 3/2004 ..... H01Q 1/32  
(Continued)

OTHER PUBLICATIONS

(21) Appl. No.: **17/916,515**

Al-Nuaimi, M. et al., "Performance Investigation of a Dual Element  
IFA Array at 3 GHz for MIMO Terminals," 2011 Loughborough  
Antennas and Propagation Conference, Nov. 14-15, 2011,  
Loughborough, UK, 5 pages.

(22) PCT Filed: **Apr. 6, 2020**

(Continued)

(86) PCT No.: **PCT/EP2020/059769**

§ 371 (c)(1),

(2) Date: **Sep. 30, 2022**

*Primary Examiner* — Hai V Tran

(74) *Attorney, Agent, or Firm* — Slater Matsil, LLP

(87) PCT Pub. No.: **WO2021/204349**

PCT Pub. Date: **Oct. 14, 2021**

(57) **ABSTRACT**

(65) **Prior Publication Data**

US 2023/0187827 A1 Jun. 15, 2023

An antenna arrangement—comprising a differential mode  
antenna—and a common mode antenna, the antenna  
arrangement—comprising an antenna structure comprising  
one radiating element, at least one differential antenna feed  
configured to induce differential mode currents in the radiating  
element, and at least one common antenna feed config-  
ured to induce common mode currents in the radiating  
element. The antenna structure is configured to excite a first  
radiofrequency range and a second radiofrequency range in  
response to the differential mode currents and the common  
mode currents. The first antenna element and the second  
antenna element are configured to excite a third radiofre-  
quency range in response to the differential mode currents or  
the common mode currents. This arrangement makes it  
possible to locate two antennas in the same given volume  
while maintaining a high level of isolation between the  
antennas.

(51) **Int. Cl.**  
**H01Q 5/35** (2015.01)  
**H01Q 1/24** (2006.01)

(Continued)

(52) **U.S. Cl.**  
CPC ..... **H01Q 5/35** (2015.01); **H01Q 1/243**  
(2013.01); **H01Q 5/371** (2015.01); **H01Q 5/40**  
(2015.01); **H01Q 9/285** (2013.01); **H01Q 9/40**  
(2013.01)

(58) **Field of Classification Search**  
CPC ..... H01Q 5/35; H01Q 1/243; H01Q 5/371;  
H01Q 5/40; H01Q 9/285; H01Q 9/40  
See application file for complete search history.

**18 Claims, 3 Drawing Sheets**

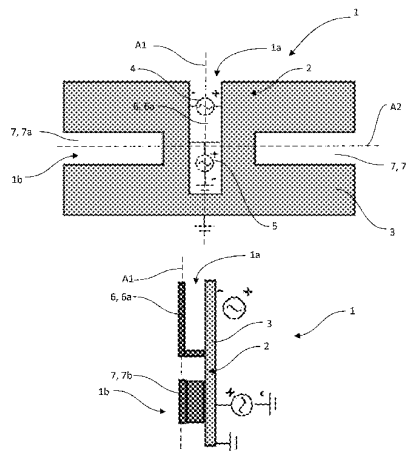



US012334653B2

(12) **United States Patent**  
**Jiang et al.**

(10) **Patent No.:** **US 12,334,653 B2**  
(45) **Date of Patent:** **Jun. 17, 2025**

(54) **ANTENNA AND ELECTRONIC DEVICE**  
(71) Applicants: **BOE TECHNOLOGY GROUP CO., LTD.**, Beijing (CN); **Beijing BOE Sensor Technology Co., Ltd.**, Beijing (CN); **Research Institute of Millimeter Wave and Terahertz Technology**, Jiangsu (CN)

(72) Inventors: **Zhihao Jiang**, Beijing (CN); **Xinyu Wu**, Beijing (CN); **Fengshuo Wan**, Beijing (CN); **Hongyuan Feng**, Beijing (CN); **Jing Xie**, Beijing (CN); **Wenjin Gao**, Beijing (CN); **Meng Wei**, Beijing (CN); **Longzhu Cai**, Beijing (CN); **Chuncheng Che**, Beijing (CN); **Wei Hong**, Beijing (CN)

(73) Assignees: **BOE TECHNOLOGY GROUP CO., LTD.**, Beijing (CN); **Beijing BOE Sensor Technology Co., Ltd.**, Beijing (CN); **Research Institute of Millimeter Wave and Terahertz Technology**, Jiangsu (CN)

(\*) Notice: Subject to any disclaimer, the term of this patent is extended or adjusted under 35 U.S.C. 154(b) by 0 days.

(21) Appl. No.: **18/027,726**  
(22) PCT Filed: **Apr. 29, 2022**  
(86) PCT No.: **PCT/CN2022/090497**  
§ 371 (c)(1),  
(2) Date: **Mar. 22, 2023**  
(87) PCT Pub. No.: **WO2023/206438**  
PCT Pub. Date: **Nov. 2, 2023**

(65) **Prior Publication Data**  
US 2024/0304995 A1 Sep. 12, 2024

(51) **Int. Cl.**  
**H01Q 3/36** (2006.01)  
**H01P 1/18** (2006.01)  
(Continued)

(52) **U.S. Cl.**  
CPC ..... **H01Q 9/0414** (2013.01); **H01Q 1/22** (2013.01); **H01Q 1/48** (2013.01); **H01Q 3/36** (2013.01)

(58) **Field of Classification Search**  
CPC ..... H01Q 1/22; H01Q 1/48; H01Q 3/36; H01Q 9/04; H01Q 9/0414; H01Q 1/38; H01Q 1/50; H01Q 21/06; H01Q 21/065  
See application file for complete search history.

(56) **References Cited**  
**U.S. PATENT DOCUMENTS**  
11,424,520 B2 \* 8/2022 Hu ..... G02F 1/1343  
11,545,750 B2 \* 1/2023 Xi ..... H01Q 3/36  
(Continued)

**FOREIGN PATENT DOCUMENTS**  
CN 104409855 A 3/2015  
CN 106154603 A 11/2016  
(Continued)

*Primary Examiner* — Tho G Phan  
(74) *Attorney, Agent, or Firm* — HOUTTEMAN LAW LC

(57) **ABSTRACT**  
An antenna and an electronic device are provided. The antenna includes a phase shifting unit, a reference electrode layer, and an antenna substrate; the phase shifting unit includes at least one phase shifter, each includes a first transmission structure, a second transmission structure, and a phase shifting structure therebetween; the reference electrode layer is provided with at least one and second first openings; the antenna substrate includes a first dielectric substrate, and a feed structure and at least one first radiation portion on a side of the first dielectric substrate away from the reference electrode layer; the feed structure includes at least one first and second feed ports; for each phase shifter,  
(Continued)

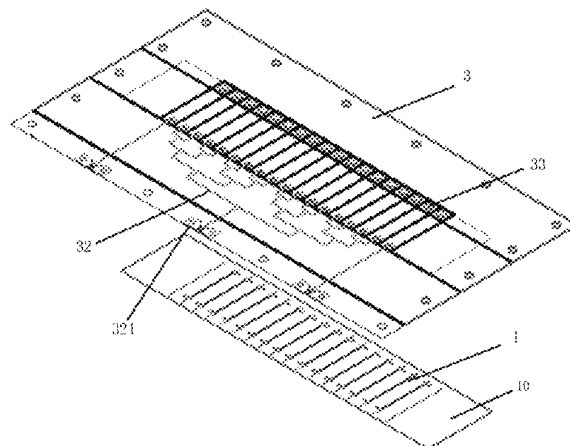



US012334654B2

(12) **United States Patent**  
**Liu et al.**

(10) **Patent No.:** **US 12,334,654 B2**  
(45) **Date of Patent:** **Jun. 17, 2025**

(54) **NETWORK COMMUNICATION DEVICE WITH ANTENNA FRAME**

FOREIGN PATENT DOCUMENTS

- (71) Applicant: **Sercomm Corporation**, Taipei (TW)
- (72) Inventors: **Hsien-Wen Liu**, Taipei (TW);  
**Chih-Wen Tseng**, Taipei (TW)
- (73) Assignee: **Sercomm Corporation**, Taipei (TW)
- (\*) Notice: Subject to any disclaimer, the term of this patent is extended or adjusted under 35 U.S.C. 154(b) by 133 days.

CN	1201436	5/2005
CN	201072802	6/2008
CN	201130704	10/2008
CN	201805457	4/2011
CN	206388838	8/2017
CN	206558668	10/2017
CN	206628586	11/2017
CN	210866466	6/2020
CN	210979760	7/2020
CN	214256755	9/2021
CN	215266646	12/2021
TW	M408141	7/2011
TW	201251192	12/2012
TW	M561335	6/2018

(21) Appl. No.: **18/182,396**

(22) Filed: **Mar. 13, 2023**

OTHER PUBLICATIONS

(65) **Prior Publication Data**  
US 2023/0327340 A1 Oct. 12, 2023

“Office Action of China Counterpart Application”, issued on Apr. 11, 2025, p. 1-p. 8.

(30) **Foreign Application Priority Data**

\* cited by examiner

Apr. 8, 2022 (CN) ..... 202210366292.5

*Primary Examiner* — Graham P Smith

(51) **Int. Cl.**  
**H01Q 9/04** (2006.01)  
**H01Q 1/12** (2006.01)

(74) *Attorney, Agent, or Firm* — JCIPRNET

(52) **U.S. Cl.**  
CPC ..... **H01Q 9/0414** (2013.01); **H01Q 1/12** (2013.01)

(57) **ABSTRACT**

(58) **Field of Classification Search**  
CPC ..... H01Q 9/0414; H01Q 1/12  
See application file for complete search history.

A network communication device having an antenna frame includes a circuit board, a network communication chip, an antenna, a signal cable and an antenna frame. The network communication chip is disposed on the circuit board. The signal cable is electrically connected to the antenna and the circuit board. The antenna frame is assembled on the circuit board. The antenna frame has a slot. The antenna is engaged in the slot. The antenna is directly fixed on the circuit board through the antenna frame, and the assembling of the antenna is easy to complete.

(56) **References Cited**

U.S. PATENT DOCUMENTS

2012/0188140 A1\* 7/2012 Bin Jamlus ..... H01Q 9/285 343/795

**6 Claims, 11 Drawing Sheets**

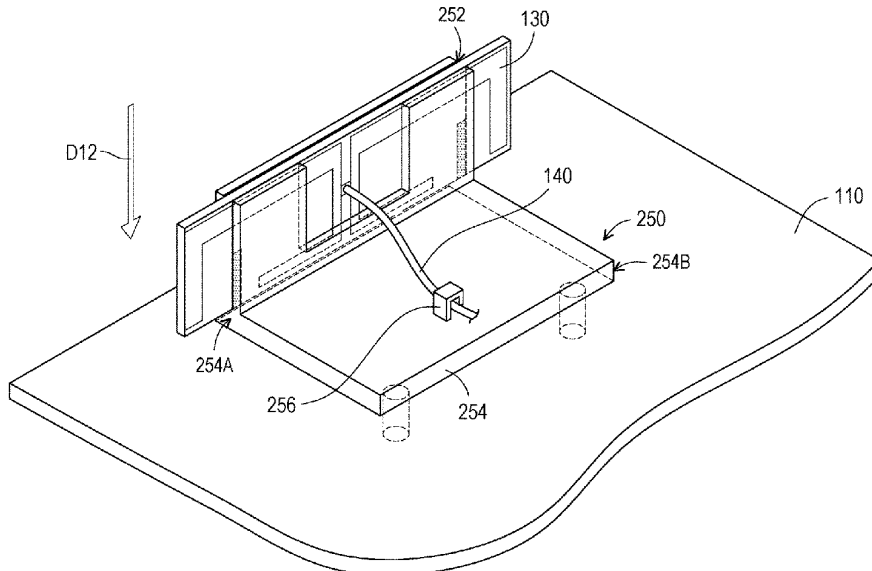





US012334656B2

(12) **United States Patent**  
**Wang**

(10) **Patent No.:** **US 12,334,656 B2**  
(45) **Date of Patent:** **Jun. 17, 2025**

(54) **ANTENNA ASSEMBLY AND ELECTRONIC DEVICE**

(71) Applicant: **GUANGDONG OPPO MOBILE TELECOMMUNICATIONS CORP., LTD.**, Guangdong (CN)

(72) Inventor: **Zedong Wang**, Guangdong (CN)

(73) Assignee: **GUANGDONG OPPO MOBILE TELECOMMUNICATIONS CORP., LTD.**, Guangdong (CN)

(\* ) Notice: Subject to any disclaimer, the term of this patent is extended or adjusted under 35 U.S.C. 154(b) by 228 days.

(21) Appl. No.: **18/346,432**

(22) Filed: **Jul. 3, 2023**

(65) **Prior Publication Data**  
US 2023/0344133 A1 Oct. 26, 2023

**Related U.S. Application Data**  
(63) Continuation of application No. PCT/CN2021/130363, filed on Nov. 12, 2021.

(30) **Foreign Application Priority Data**  
Jan. 7, 2021 (CN) ..... 202110021880.0

(51) **Int. Cl.**  
**H01Q 9/04** (2006.01)  
**H01Q 1/22** (2006.01)  
(52) **U.S. Cl.**  
CPC ..... **H01Q 9/0457** (2013.01); **H01Q 1/22** (2013.01)

(58) **Field of Classification Search**  
CPC ..... H01Q 5/30; H01Q 5/335; H01Q 5/342; H01Q 9/0407; H01Q 9/0442; H01Q 9/0457

See application file for complete search history.

(56) **References Cited**

U.S. PATENT DOCUMENTS

9,124,006 B2 9/2015 Ding  
2004/0145525 A1 7/2004 Annabi et al.  
(Continued)

FOREIGN PATENT DOCUMENTS

CN 203225342 10/2013  
CN 105305046 2/2016  
(Continued)

OTHER PUBLICATIONS

CNIPA, First Office Action for CN Application No. 202110021880.0, Nov. 28, 2022.

(Continued)

*Primary Examiner* — Jason M Crawford  
(74) *Attorney, Agent, or Firm* — Hodgson Russ LLP

(57) **ABSTRACT**

An antenna assembly and an electronic device are provided. The antenna assembly includes a substrate, a radiating patch, and a matching structure. The radiating patch is disposed on the substrate. The matching structure is configured to be electrically connected with a radio frequency (RF) signal circuit at one end of the matching structure, and the matching structure is provided with a first coupling piece at the other end of the matching structure. The first coupling piece is in capacitive coupling with the radiating patch. The first coupling piece is configured to feed a RF signal generated by the RF signal circuit into the radiating patch, to excite the radiating patch to generate multiple resonant modes. At least one resonant mode in the multiple resonant modes is generated by the capacitive coupling between the first coupling piece and the radiating patch.

**20 Claims, 11 Drawing Sheets**

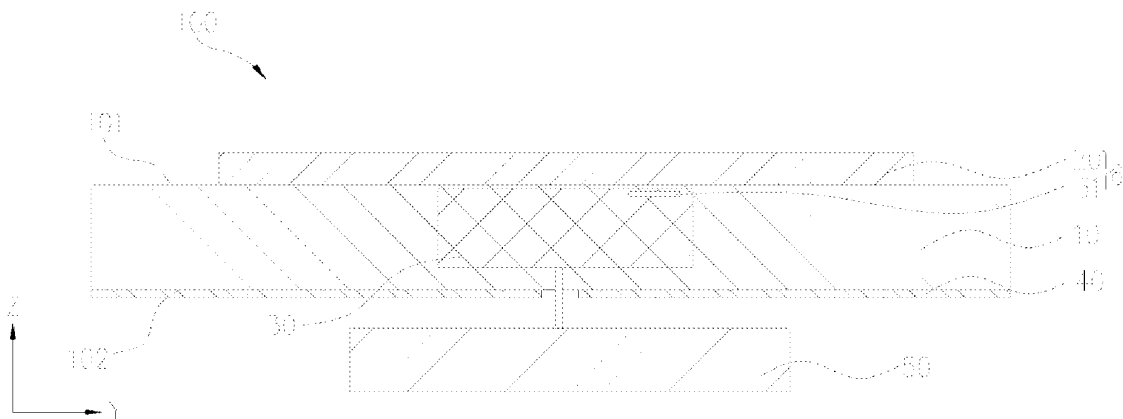



US012334896B2

(12) **United States Patent**  
**Mori**

(10) **Patent No.:** **US 12,334,896 B2**  
(45) **Date of Patent:** **Jun. 17, 2025**

(54) **MULTIPLEXER AND ANTENNA MODULE**  
(71) Applicant: **Murata Manufacturing Co., Ltd.**,  
Nagaokakyo (JP)  
(72) Inventor: **Hirotsugu Mori**, Nagaokakyo (JP)  
(73) Assignee: **MURATA MANUFACTURING CO., LTD.**,  
Nagaokakyo (JP)  
(\* ) Notice: Subject to any disclaimer, the term of this  
patent is extended or adjusted under 35  
U.S.C. 154(b) by 267 days.

(21) Appl. No.: **17/967,917**  
(22) Filed: **Oct. 18, 2022**  
(65) **Prior Publication Data**  
US 2023/0035579 A1 Feb. 2, 2023  
**Related U.S. Application Data**  
(63) Continuation of application No.  
PCT/JP2021/003247, filed on Jan. 29, 2021.

(30) **Foreign Application Priority Data**  
Apr. 24, 2020 (JP) ..... 2020-077503  
(51) **Int. Cl.**  
**H03H 7/46** (2006.01)  
**H01Q 21/30** (2006.01)  
(Continued)  
(52) **U.S. Cl.**  
CPC ..... **H03H 7/46** (2013.01); **H01Q 21/30**  
(2013.01); **H03H 7/0115** (2013.01);  
(Continued)  
(58) **Field of Classification Search**  
CPC ..... H03H 7/46; H03H 7/0115; H03H 7/0163;  
H03H 7/463  
(Continued)

(56) **References Cited**  
U.S. PATENT DOCUMENTS  
2019/0280668 A1\* 9/2019 Harada ..... H04B 1/0057  
2020/0014370 A1\* 1/2020 Matsubara ..... H03H 9/568  
FOREIGN PATENT DOCUMENTS  
JP 59-126304 A 7/1984  
JP 5-39003 U 5/1993  
(Continued)

**OTHER PUBLICATIONS**  
Written Opinion of the International Searching Authority mailed on  
Mar. 16, 2021, received for PCT Application PCT/JP2021/003247,  
filed on Jan. 29, 2021, 3 pages. (Previously filed; submitting English  
translation only.)  
(Continued)  
*Primary Examiner* — Rakesh B Patel  
(74) *Attorney, Agent, or Firm* — XSENSUS LLP

(57) **ABSTRACT**  
A common line is connected between a common terminal  
and a common connection node. A first filter has a first pass  
band. A second filter has a second pass band. At least one of  
a first condition and a second condition is satisfied. The first  
condition is that in the first pass band any one of a first  
impedance of the common line alone viewed from the  
common terminal (P10) and a second impedance of the first  
filter viewed from the common connection node includes an  
inductive property and the other includes a capacitive prop-  
erty. The second condition is that in the second pass band  
one of the first impedance and a third impedance of the  
second filter viewed from the common connection node  
includes an inductive property and the other includes a  
capacitive property.

**17 Claims, 43 Drawing Sheets**

1A

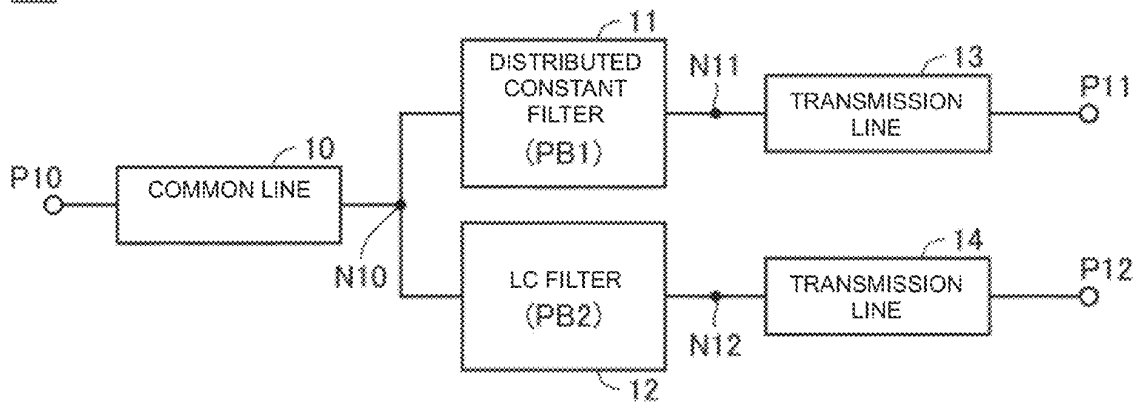



US012334959B2

(12) **United States Patent**  
**Pehlke et al.**

(10) **Patent No.:** **US 12,334,959 B2**  
(45) **Date of Patent:** **Jun. 17, 2025**

(54) **APPARATUS AND METHODS FOR  
DIPLEXING BY ANTENNA STRUCTURE**

5/307; H01Q 5/42; H01Q 9/0407; H01Q  
9/0421; H01Q 9/42; H01Q 21/061; H01Q  
21/065; H01Q 21/28; H04W 88/00;  
H04W 88/02; H04W 88/04; H04W 88/06  
See application file for complete search history.

(71) Applicant: **Skyworks Solutions, Inc.**, Irvine, CA  
(US)

(72) Inventors: **David Richard Pehlke**, Westlake  
Village, CA (US); **Paul T. DiCarlo**,  
Marlborough, MA (US); **Grant Darcy  
Poulin**, Carp (CA)

(56) **References Cited**

U.S. PATENT DOCUMENTS

4,035,797	A	7/1977	Nagy	
6,747,592	B2	6/2004	Nakamura	
7,120,465	B2	10/2006	Skarby et al.	
8,941,547	B2	1/2015	Cho et al.	
10,530,052	B2*	1/2020	Sudo	H01Q 5/50
2016/0043750	A1	2/2016	Borlenghi	
2019/0372628	A1*	12/2019	Balteanu	H04B 7/0848

(Continued)

(73) Assignee: **Skyworks Solutions, Inc.**, Irvine, CA  
(US)

(\* ) Notice: Subject to any disclaimer, the term of this  
patent is extended or adjusted under 35  
U.S.C. 154(b) by 606 days.

*Primary Examiner* — Frank Duong

(21) Appl. No.: **17/658,231**

(74) *Attorney, Agent, or Firm* — Knobbe, Martens, Olson  
& Bear, LLP

(22) Filed: **Apr. 6, 2022**

(65) **Prior Publication Data**

US 2022/0329270 A1 Oct. 13, 2022

**Related U.S. Application Data**

(60) Provisional application No. 63/201,010, filed on Apr.  
8, 2021.

(57) **ABSTRACT**

Apparatus and methods for diplexing by antenna structure  
are provided. In certain embodiments, a mobile device  
includes a front end system and an antenna structure. The  
front end system includes a first signal conditioning circuit  
configured to condition a first radio frequency signal of a  
first frequency, and a second signal conditioning circuit  
configured to condition a second radio frequency signal of a  
second frequency that is lower than the first frequency. The  
antenna structure is configured to diplex the first radio  
frequency signal and the second radio frequency signal, and  
includes a first antenna configured to handle the first radio  
frequency signal and a second antenna electromagnetically  
coupled to the first antenna and configured to handle the  
second radio frequency signal.

(51) **Int. Cl.**  
**H04W 88/02** (2009.01)  
**H01Q 5/307** (2015.01)  
**H01Q 9/04** (2006.01)  
**H04B 1/00** (2006.01)

(52) **U.S. Cl.**  
CPC ..... **H04B 1/0057** (2013.01); **H01Q 5/307**  
(2015.01); **H01Q 9/0407** (2013.01)

(58) **Field of Classification Search**  
CPC ..... H04B 1/0057; H04B 1/0064; H01Q  
1/2283; H01Q 1/241; H01Q 1/247; H01Q

**20 Claims, 13 Drawing Sheets**

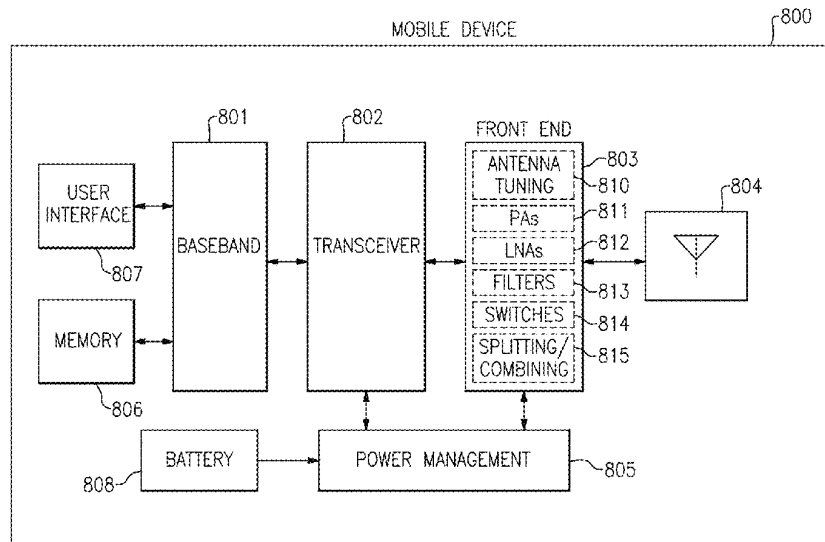



US012334960B2

(12) **United States Patent**  
**Luo et al.**

(10) **Patent No.:** **US 12,334,960 B2**  
(45) **Date of Patent:** **Jun. 17, 2025**

(54) **CONFIGURABLE RADIO FREQUENCY (RF) MULTIPLEXING SWITCH FOR RF FRONT END IN 4G/5G APPLICATIONS**

G01S 13/87; G01S 13/00; G01S 13/76; G01S 5/02; H04L 43/0864; H04L 1/0003; H04L 1/0009; H04L 1/0026; H04L 1/1816; H04L 1/1822; H04L 1/1861; H04L 12/1868; H04L 2001/0093; H04L 5/0055;

(71) Applicant: **Avago Technologies International Sales Pte. Limited**, Singapore (SG)

(Continued)

(72) Inventors: **Yuan Luo**, Los Gatos, CA (US); **Yalin Jin**, San Jose, CA (US); **Shang Wang**, Milpitas, CA (US); **Jeesu Kim**, San Ramon, CA (US)

(56)

**References Cited**

U.S. PATENT DOCUMENTS

(73) Assignee: **Avago Technologies International Sales Pte. Limited**, Palo Alto, CA (US)

7,251,499 B2 7/2007 Ellä et al.  
8,385,876 B2 2/2013 Goto et al.  
(Continued)

(\* ) Notice: Subject to any disclaimer, the term of this patent is extended or adjusted under 35 U.S.C. 154(b) by 319 days.

FOREIGN PATENT DOCUMENTS

(21) Appl. No.: **17/872,912**

JP 2011166663 A 8/2011  
WO WO-2022056150 A1 \* 3/2022 ..... H03F 1/565

(22) Filed: **Jul. 25, 2022**

*Primary Examiner* — Nathan S Taylor  
(74) *Attorney, Agent, or Firm* — Quarles & Brady LLP

(65) **Prior Publication Data**

US 2024/0030944 A1 Jan. 25, 2024

(57) **ABSTRACT**

(51) **Int. Cl.**  
**H04B 1/00** (2006.01)  
**H04B 1/04** (2006.01)  
**H04B 1/30** (2006.01)

An RF multiplexing switching circuit for an RF front end (e.g., for a mobile communications device transmitting/receiving in the RF region) includes a set of RF inputs and a set of RF outputs outputting to RF filters, the RF inputs and outputs connected by signal paths. The switching circuit includes series switches for creating conducting signal paths for transmitting/receiving RF signals between the RF inputs and outputs, and a set of common shared shunt switches (e.g., for M RF inputs and N RF outputs, M+X shunt switches, where X<N) collectively capable (e.g., in conjunction with the series switches) of pulling to ground potential any RF input and output not on the conducting signal path. The RF switching circuit may be implemented as a band select switch (e.g., where the inputs connect to power amplifiers) or an antenna switch (e.g., where the inputs connect to device antennas).

(52) **U.S. Cl.**  
CPC ..... **H04B 1/0057** (2013.01); **H04B 1/006** (2013.01); **H04B 1/04** (2013.01); **H04B 1/30** (2013.01);

(Continued)

(58) **Field of Classification Search**  
CPC ..... H04W 56/005; H04W 56/00; H04W 72/1268; H04W 74/0833; H04W 74/0841; H04W 74/0866; H04W 74/08; H04W 72/12; H04W 4/06; H04W 76/40; G01S 13/003; G01S 13/765; G01S 13/767;

**20 Claims, 7 Drawing Sheets**

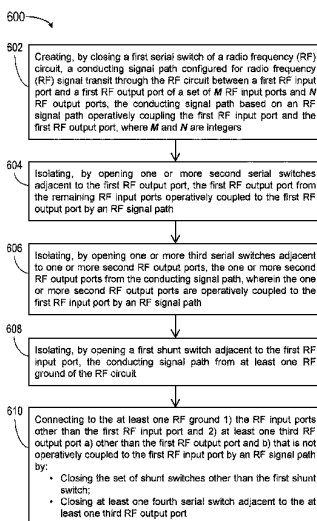



US012334998B2

(12) **United States Patent**  
**Sachidanand Sinha et al.**

(10) **Patent No.:** **US 12,334,998 B2**  
(45) **Date of Patent:** **Jun. 17, 2025**

- (54) **CAPABILITY FOR MULTIPLE BEAMFORMING CODEBOOKS**
- (71) Applicant: **QUALCOMM Incorporated**, San Diego, CA (US)
- (72) Inventors: **Abhishek Saurabh Sachidanand Sinha**, San Diego, CA (US); **Deepak Agarwal**, San Diego, CA (US); **Michael Francis Garyantes**, Bradley Beach, NJ (US); **Rohan Salvi**, San Diego, CA (US); **Orod Raeesi**, Uusimaa (FI); **James Krysl**, San Diego, CA (US); **Senthilkumar Sundaram**, San Diego, CA (US); **Kalyan Kuppuswamy**, San Diego, CA (US)
- (73) Assignee: **QUALCOMM Incorporated**, San Diego, CA (US)
- (\*) Notice: Subject to any disclaimer, the term of this patent is extended or adjusted under 35 U.S.C. 154(b) by 0 days.
- (21) Appl. No.: **17/820,057**
- (22) Filed: **Aug. 16, 2022**
- (65) **Prior Publication Data**  
US 2024/0063851 A1 Feb. 22, 2024
- (51) **Int. Cl.**  
**H04B 7/0456** (2017.01)  
**H04B 7/06** (2006.01)
- (52) **U.S. Cl.**  
CPC ..... **H04B 7/0456** (2013.01); **H04B 7/0617** (2013.01)
- (58) **Field of Classification Search**  
CPC ..... H04B 7/0456; H04B 7/0617  
USPC ..... 375/267  
See application file for complete search history.

- (56) **References Cited**  
U.S. PATENT DOCUMENTS
- 10,931,339 B2 \* 2/2021 Huang ..... H04B 7/0456
- 2015/0289147 A1 \* 10/2015 Lou ..... H04B 7/0634 370/329
- 2019/0052345 A1 \* 2/2019 Yunoki ..... H04B 7/0695
- 2019/0141744 A1 \* 5/2019 Naghshvar ..... H04B 7/0452
- 2020/0287602 A1 9/2020 Park et al.
- 2021/0111772 A1 \* 4/2021 Lee ..... H04B 7/0452
- 2021/0273747 A1 \* 9/2021 MacKenzie ..... H04L 1/0078
- 2023/0160936 A1 \* 5/2023 Obermaier ..... G01R 29/0871 343/702
- 2024/0039813 A1 \* 2/2024 Agarwal ..... H04L 43/08

- FOREIGN PATENT DOCUMENTS
- WO WO-2020242355 A1 \* 12/2020 ..... H01Q 1/523
- WO WO-2020248794 A1 \* 12/2020

OTHER PUBLICATIONS

International Search Report and Written Opinion—PCT/US2023/029758—ISA/EPO—Nov. 20, 2023.

\* cited by examiner

*Primary Examiner* — Leila Malek  
(74) *Attorney, Agent, or Firm* — Guang Y. Zhang; Harrity & Harrity, LLP

(57) **ABSTRACT**

Various aspects of the present disclosure generally relate to wireless communication. In some aspects, a radio unit may output capability information regarding a number of beamforming codebooks supported by the radio unit. The radio unit may obtain configuration information that configures one or more beamforming codebooks for an antenna array of the radio unit. The radio unit may communicate using the one or more beamforming codebooks. Numerous other aspects are described.

**29 Claims, 13 Drawing Sheets**

400 →

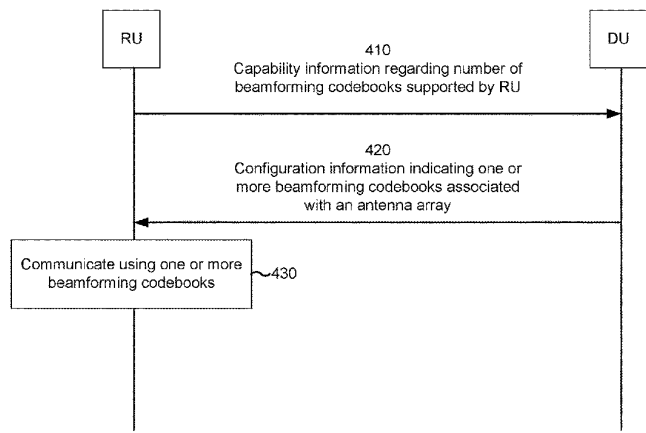



US012335019B2

(12) **United States Patent**  
**Baldemair et al.**

(10) **Patent No.:** **US 12,335,019 B2**  
(45) **Date of Patent:** **Jun. 17, 2025**

(54) **METHOD AND APPARATUS FOR ARRAY SIZE INVARIANT BEAMFORMING**

(56) **References Cited**

U.S. PATENT DOCUMENTS

(71) Applicant: **Telefonaktiebolaget LM Ericsson (publ)**, Stockholm (SE)

2019/0280748 A1 9/2019 Cirkcic et al.  
2020/0395664 A1\* 12/2020 Athley ..... H04B 7/0617

(72) Inventors: **Robert Baldemair**, Solna (SE); **Sven Petersson**, Sävedalen (SE)

FOREIGN PATENT DOCUMENTS

(73) Assignee: **Telefonaktiebolaget LM Ericsson (Publ)**, Stockholm (SE)

WO 2020214071 A1 10/2020

OTHER PUBLICATIONS

(\* ) Notice: Subject to any disclaimer, the term of this patent is extended or adjusted under 35 U.S.C. 154(b) by 4 days.

International Search Report and Written Opinion dated Oct. 1, 2021 for International Application No. PCT/SE2021/050013 filed Jan. 12, 2021, consisting of 12-pages.

(21) Appl. No.: **18/260,565**

(Continued)

(22) PCT Filed: **Jan. 12, 2021**

*Primary Examiner* — Rahel Guarino

(86) PCT No.: **PCT/SE2021/050013**

(74) *Attorney, Agent, or Firm* — Weisberg I.P. Law, P.A.

§ 371 (c)(1),  
(2) Date: **Jul. 6, 2023**

(57) **ABSTRACT**

(87) PCT Pub. No.: **WO2022/154699**

PCT Pub. Date: **Jul. 21, 2022**

Methods for transmitting a first signal x1 and a second signal x2 using a first array of antenna elements of a polarization A and a second array of antenna elements of a substantially orthogonal polarization B. The methods include transmitting x1 in a first beam generated with array size invariant beamforming, using a sub-array A1 of antenna elements from the first array and applying a first precoding matrix, and using a sub-array B1 of antenna elements from the second array and applying a second precoding matrix. The methods also include transmitting x2 in a second beam generated with array size invariant beamforming, using a sub-array A2 of antenna elements from the first array and applying a third precoding matrix, and using a sub-array B2 of antenna elements from the second array and applying a fourth precoding matrix. The sub-arrays within a polarization are typically non-overlapping.

(65) **Prior Publication Data**

US 2024/0072879 A1 Feb. 29, 2024

(51) **Int. Cl.**  
**H04B 7/10** (2017.01)  
**H04B 7/0456** (2017.01)

(52) **U.S. Cl.**  
CPC ..... **H04B 7/10** (2013.01); **H04B 7/0469** (2013.01)

(58) **Field of Classification Search**  
CPC ..... H04B 7/10; H04B 7/0469  
See application file for complete search history.

**20 Claims, 8 Drawing Sheets**

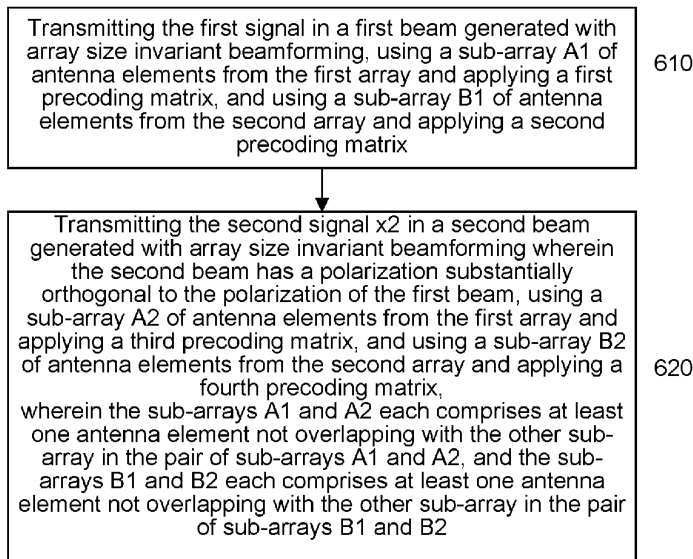



US012335182B2

(12) **United States Patent**  
**Huang et al.**

(10) **Patent No.:** **US 12,335,182 B2**  
(45) **Date of Patent:** **Jun. 17, 2025**

(54) **SIGNAL TRANSMISSION METHOD AND APPARATUS, AND STORAGE MEDIUM**

(58) **Field of Classification Search**  
CPC ..... H04W 28/0215; H04W 28/0226; H04W 28/0231; H04W 28/0273; H04W 28/0289;  
(Continued)

(71) Applicant: **DATANG MOBILE COMMUNICATIONS EQUIPMENT CO., LTD.**, Beijing (CN)

(56) **References Cited**

(72) Inventors: **Qiuping Huang**, Beijing (CN); **Qiubin Gao**, Beijing (CN)

U.S. PATENT DOCUMENTS

(73) Assignee: **DATANG MOBILE COMMUNICATIONS EQUIPMENT CO., LTD.**, Beijing (CN)

2012/0113869 A1 5/2012 Gaal et al.  
2019/0174466 A1 6/2019 Zhang et al.  
(Continued)

FOREIGN PATENT DOCUMENTS

(\*) Notice: Subject to any disclaimer, the term of this patent is extended or adjusted under 35 U.S.C. 154(b) by 275 days.

CN 109923828 A 6/2019  
CN 110474734 A 11/2019  
(Continued)

(21) Appl. No.: **18/020,079**

OTHER PUBLICATIONS

(22) PCT Filed: **Aug. 5, 2021**

Nokia, "Introduction of NR enhanced MIMO", 3GPP TSG-RAN WG1 Meeting #99, Reno, USA, Nov. 18-22, 2019, total 51 pages, R1-1913655.

(86) PCT No.: **PCT/CN2021/110721**

§ 371 (c)(1),  
(2) Date: **Feb. 6, 2023**

(Continued)

(87) PCT Pub. No.: **WO2022/028501**

PCT Pub. Date: **Feb. 10, 2022**

*Primary Examiner* — Phong La  
(74) *Attorney, Agent, or Firm* — KILPATRICK TOWNSEND & STOCKTON LLP

(65) **Prior Publication Data**

US 2023/0308234 A1 Sep. 28, 2023

(57) **ABSTRACT**

(30) **Foreign Application Priority Data**

Aug. 7, 2020 (CN) ..... 202010791708.9

Provided are a signal transmission method and apparatus, and a storage medium. The method includes determining a first determination mode and/or a second determination mode, and the first determination mode is a mode for determining first SRS transmission corresponding to an uplink signal, and the second determination method is a mode for determining a first antenna port corresponding to the uplink signal; and transmitting the first determination mode and/or the second determination mode to a UE, and the UE determines the first SRS transmission according to the first determination mode, and/or determines the first antenna port according to the second determination mode,  
(Continued)

(51) **Int. Cl.**  
**H04L 5/00** (2006.01)  
**H04B 7/06** (2006.01)  
**H04W 28/02** (2009.01)

(52) **U.S. Cl.**  
CPC ..... **H04L 5/0048** (2013.01); **H04B 7/0602** (2013.01); **H04W 28/0215** (2013.01)

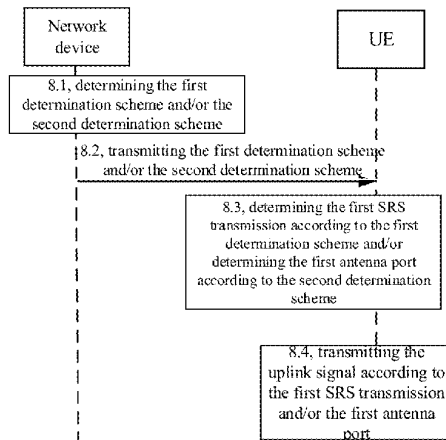



US012335751B2

(12) **United States Patent**  
**Gao et al.**

(10) **Patent No.:** **US 12,335,751 B2**  
(45) **Date of Patent:** **Jun. 17, 2025**

(54) **METHOD FOR UPLINK TRANSMISSION ASSOCIATED WITH ANTENNA PORT AND PANEL SWITCHING**

H04L 5/0048; H04B 7/0404; H04B 7/0602; H04B 7/0695; H04B 7/088; H04B 7/0691

See application file for complete search history.

(71) Applicant: **ZTE CORPORATION**, Guangdong (CN)

(56) **References Cited**

(72) Inventors: **Bo Gao**, Shenzhen (CN); **Zhaohua Lu**, Shenzhen (CN); **Hao Wu**, Shenzhen (CN); **Chuangxin Jiang**, Shenzhen (CN); **Wenjun Yan**, Shenzhen (CN)

U.S. PATENT DOCUMENTS

2005/0249159 A1 11/2005 Abraham et al.  
2019/0103908 A1 4/2019 Yu et al.  
2019/0281588 A1 9/2019 Zhang et al.  
2019/0297603 A1 9/2019 Guo et al.

(Continued)

(73) Assignee: **ZTE Corporation**, Shenzhen (CN)

(\* ) Notice: Subject to any disclaimer, the term of this patent is extended or adjusted under 35 U.S.C. 154(b) by 175 days.

FOREIGN PATENT DOCUMENTS

CN 103001732 A 3/2013  
CN 108112075 A 6/2018  
CN 110324884 A 10/2019

(Continued)

(21) Appl. No.: **17/855,409**

(22) Filed: **Jun. 30, 2022**

OTHER PUBLICATIONS

International Search Report and Written Opinion for PCT Appl. No. PCT/CN2020/104352, mailed Apr. 2, 2021 (8 pages).

(Continued)

(65) **Prior Publication Data**

US 2022/0338027 A1 Oct. 20, 2022

**Related U.S. Application Data**

(63) Continuation of application No. PCT/CN2020/104352, filed on Jul. 24, 2020.

*Primary Examiner* — Eric Myers

(74) *Attorney, Agent, or Firm* — Foley & Lardner LLP

(51) **Int. Cl.**  
**H04W 16/28** (2009.01)  
**H04L 5/00** (2006.01)  
**H04W 74/08** (2024.01)  
**H04W 74/0816** (2024.01)

(57) **ABSTRACT**

A wireless communication method for use in a wireless terminal is disclosed. The wireless communication method comprises determining at least one transmission state for an uplink channel, wherein at least one of a spatial relation or an antenna port of the uplink channel is determined based on a first transmission state of the at least one transmission state, and transmitting, to a wireless network node, the uplink channel.

(52) **U.S. Cl.**  
CPC ..... **H04W 16/28** (2013.01); **H04L 5/0051** (2013.01); **H04W 74/0816** (2013.01); **H04W 74/0866** (2013.01)

(58) **Field of Classification Search**  
CPC ..... H04W 16/28; H04W 74/0816; H04W 74/0866; H04L 5/0051; H04L 5/0025;

**16 Claims, 8 Drawing Sheets**

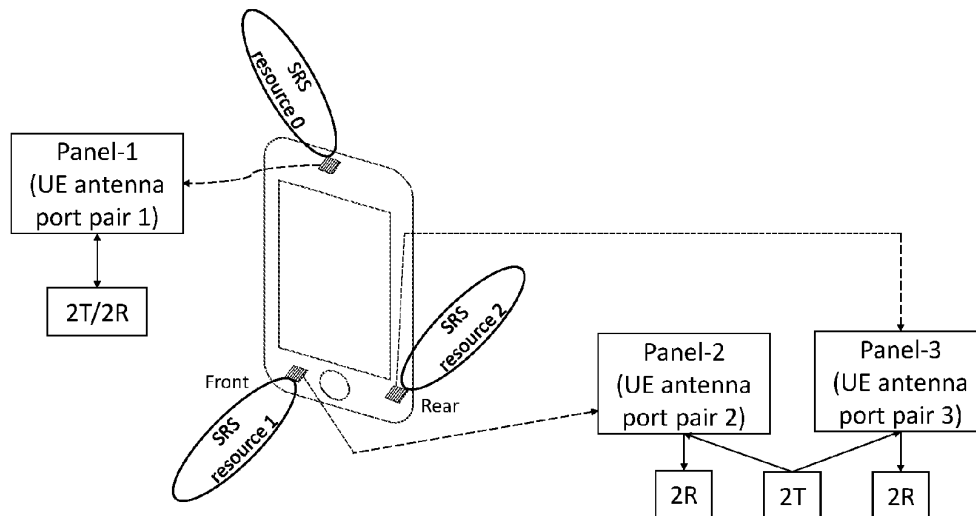



US012335762B2

(12) **United States Patent**  
**Lee et al.**

(10) **Patent No.:** **US 12,335,762 B2**  
(45) **Date of Patent:** **Jun. 17, 2025**

(54) **ELECTRONIC DEVICE PERFORMING MEASUREMENT ON MEASUREMENT OBJECT OF INTER-RAT AND METHOD FOR OPERATING THE SAME**

(58) **Field of Classification Search**  
CPC .... H04W 24/10; H04W 24/08; H04W 36/144  
See application file for complete search history.

(71) Applicant: **SAMSUNG ELECTRONICS CO., LTD.**, Suwon-si (KR)

(56) **References Cited**

U.S. PATENT DOCUMENTS

(72) Inventors: **Youngkwon Lee**, Suwon-si (KR); **Hyungjoon Yu**, Suwon-si (KR); **Insoo Lee**, Suwon-si (KR)

2010/0227639 A1 9/2010 Kim et al.  
2017/0019852 A1 1/2017 Yang  
(Continued)

FOREIGN PATENT DOCUMENTS

(73) Assignee: **Samsung Electronics Co., Ltd.**, Suwon-si (KR)

CN 110915252 A 3/2020  
CN 111757346 A 10/2020  
(Continued)

(\* ) Notice: Subject to any disclaimer, the term of this patent is extended or adjusted under 35 U.S.C. 154(b) by 498 days.

OTHER PUBLICATIONS

(21) Appl. No.: **17/662,563**

International Search Report dated Jul. 26, 2022 in connection with International Patent Application No. PCT/KR2022/005695, 2 pages.  
(Continued)

(22) Filed: **May 9, 2022**

*Primary Examiner* — Alex Skripnikov

(65) **Prior Publication Data**  
US 2023/0023678 A1 Jan. 26, 2023

(57) **ABSTRACT**

**Related U.S. Application Data**

(63) Continuation of application No. PCT/KR2022/005695, filed on Apr. 21, 2022.

An electronic device may comprise a plurality of antennas, at least one processor, and an RF circuit. The at least one processor may be configured to identify at least one channel measurement configuration associated with a second RAT different from a first RAT in a state in which the electronic device is connected to a first communication network based on the first RAT, perform measurement on at least one measurement object identified based on at least some of the at least one channel measurement configuration, using at least one first antenna among the plurality of antennas, detect an event requiring a switch of an antenna for performing the measurement, and control the RF circuit to perform the measurement, using at least one second antenna different from the at least one first antenna among the plurality of antennas, based on detection of the event.

(30) **Foreign Application Priority Data**

Jul. 14, 2021 (KR) ..... 10-2021-0092105

(51) **Int. Cl.**  
**H04W 24/10** (2009.01)  
**H04W 24/08** (2009.01)  
**H04W 36/14** (2009.01)

(52) **U.S. Cl.**  
CPC ..... **H04W 24/10** (2013.01); **H04W 24/08** (2013.01); **H04W 36/144** (2023.05)

**18 Claims, 20 Drawing Sheets**

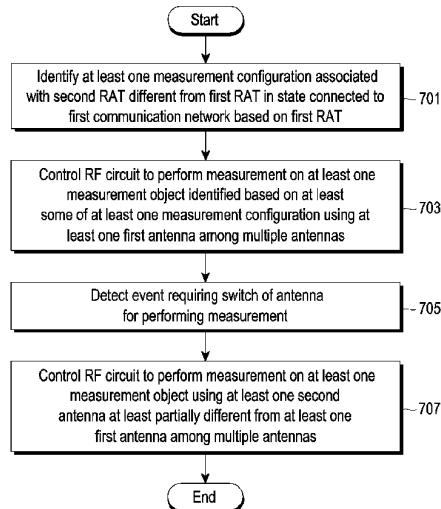



US012335795B2

(12) **United States Patent**  
**Park et al.**

(10) **Patent No.:** **US 12,335,795 B2**  
(45) **Date of Patent:** **Jun. 17, 2025**

(54) **ELECTRONIC DEVICE FOR SELECTING CELL, AND METHOD THEREFOR**

(71) Applicant: **Samsung Electronics Co., Ltd.**, Suwon-si (KR)

(72) Inventors: **Suyoung Park**, Suwon-si (KR); **Soenghun Kim**, Suwon-si (KR)

(73) Assignee: **Samsung Electronics Co., Ltd.**, Suwon-si (KR)

(\*) Notice: Subject to any disclaimer, the term of this patent is extended or adjusted under 35 U.S.C. 154(b) by 514 days.

(21) Appl. No.: **17/710,211**

(22) Filed: **Mar. 31, 2022**

(65) **Prior Publication Data**

US 2022/0225195 A1 Jul. 14, 2022

**Related U.S. Application Data**

(63) Continuation of application No. PCT/KR2020/013081, filed on Sep. 25, 2020.

(30) **Foreign Application Priority Data**

Oct. 16, 2019 (KR) ..... 10-2019-0128585

(51) **Int. Cl.**  
**H04W 36/00** (2009.01)  
**H04W 24/08** (2009.01)  
**H04W 74/0833** (2024.01)

(52) **U.S. Cl.**  
CPC ..... **H04W 36/0058** (2018.08); **H04W 24/08** (2013.01); **H04W 36/0061** (2013.01); **H04W 74/0833** (2013.01)

(58) **Field of Classification Search**  
USPC ..... 370/252, 328, 329, 330, 331, 332, 343, 370/431, 436, 437, 466  
See application file for complete search history.

(56) **References Cited**

U.S. PATENT DOCUMENTS

8,886,184 B2 11/2014 Cho et al.  
9,832,654 B2 11/2017 Koskinen et al.  
(Continued)

FOREIGN PATENT DOCUMENTS

EP 3 787 348 A1 3/2021  
EP 3 866 511 A1 8/2021  
(Continued)

OTHER PUBLICATIONS

European Office Action Apr. 3, 2024, issued in European Application No. 20 876 098.3-1216.

(Continued)

*Primary Examiner* — Nguyen H Ngo

(74) *Attorney, Agent, or Firm* — Jefferson IP Law, LLP

(57) **ABSTRACT**

An electronic device is provided. The electronic device includes an antenna, a communication module connected to the antenna, and a processor connected to the communication module, wherein the processor can confirm a frequency band supportable by the electronic device, receive, from a base station, system information including information about a peripheral cell, determine whether the peripheral cell is either an unlicensed cell or a non-terrestrial cell on the basis of the confirmed frequency band and/or the received system information, determine the priority of a frequency, which is the reference for cell selection, on the basis of at least one from among the confirmed frequency band, the received system information, and the type of determined cell, and select a cell according to the determined priority of the frequency.

**8 Claims, 20 Drawing Sheets**

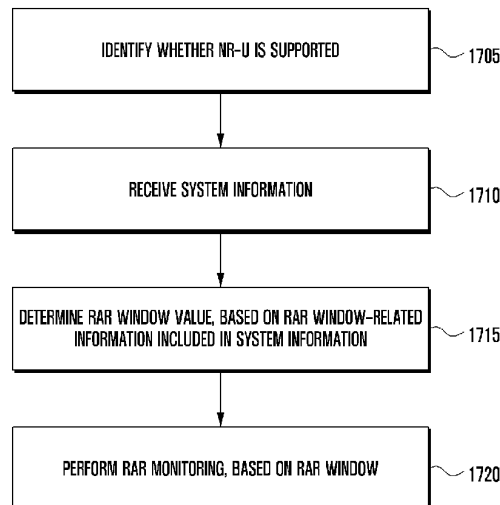



US012335849B2

(12) **United States Patent**  
**Lee et al.**

(10) **Patent No.:** **US 12,335,849 B2**  
(45) **Date of Patent:** **Jun. 17, 2025**

(54) **ELECTRONIC DEVICE AND METHOD FOR RECEIVING SYSTEM INFORMATION IN ELECTRONIC DEVICE**

(58) **Field of Classification Search**  
CPC .. H04L 12/18; H04W 48/12; H04W 36/0083; H04B 7/0413; Y02D 30/70  
See application file for complete search history.

(71) Applicant: **Samsung Electronics Co., Ltd.**, Suwon-si (KR)

(56) **References Cited**

U.S. PATENT DOCUMENTS

(72) Inventors: **Keonyoung Lee**, Suwon-si (KR); **Kwanghoo Yoon**, Suwon-si (KR)

2015/0282207 A1 10/2015 Ambriss et al.  
2016/0044488 A1 2/2016 Kim et al.

(Continued)

(73) Assignee: **Samsung Electronics Co., Ltd.**, Suwon-si (KR)

FOREIGN PATENT DOCUMENTS

(\* ) Notice: Subject to any disclaimer, the term of this patent is extended or adjusted under 35 U.S.C. 154(b) by 423 days.

JP 2016/519876 T 7/2016  
JP 2020/058058 A 4/2020

(Continued)

(21) Appl. No.: **17/726,088**

OTHER PUBLICATIONS

(22) Filed: **Apr. 21, 2022**

3GPP TS 38.331 (v16.4.1); TSG RAN; NR; Radio Resource Control (RRC) protocol specification (Release 16); Mar. 30, 2021.

(65) **Prior Publication Data**

(Continued)

US 2022/0345956 A1 Oct. 27, 2022

*Primary Examiner* — Mahran Y Abu Roumi

(74) *Attorney, Agent, or Firm* — Jefferson IP Law, LLP

**Related U.S. Application Data**

(57) **ABSTRACT**

(63) Continuation of application No. PCT/KR2022/005677, filed on Apr. 20, 2022.

An electronic device includes at least one antenna and a processor configured to transmit and receive data to and from the a base station connected by communication, through the at least one antenna, perform a handover from the first base station to a second base station, receive first system information broadcast from the second base station, identify information related to a system information request based on the first system information, identify a time point for transmitting a system information request based on a data inactivity timer, and transmit a system information request to the second base station based on the information related to a system information request at the identified time point for transmitting a system information request.

(30) **Foreign Application Priority Data**

Apr. 21, 2021 (KR) ..... 10-2021-0051617

(51) **Int. Cl.**  
**H04W 48/14** (2009.01)  
**H04W 36/00** (2009.01)  
**H04W 36/08** (2009.01)

(52) **U.S. Cl.**  
CPC ..... **H04W 48/14** (2013.01); **H04W 36/00698** (2023.05); **H04W 36/085** (2023.05)

**18 Claims, 17 Drawing Sheets**

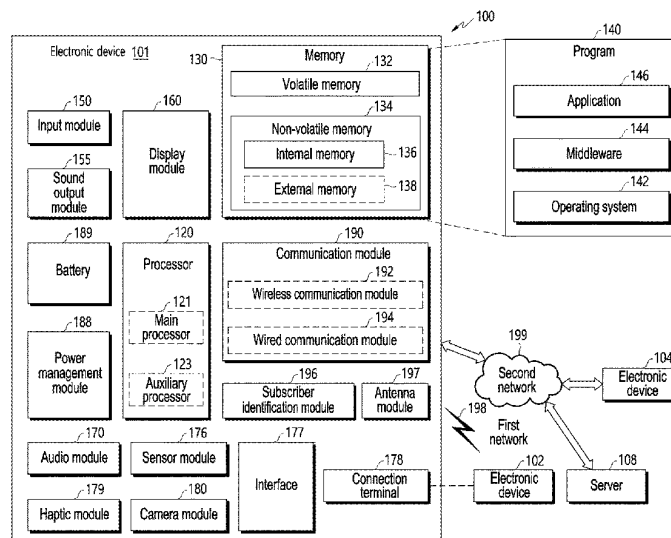



US012339714B2

(12) **United States Patent**  
**Chang et al.**

(10) **Patent No.:** **US 12,339,714 B2**  
(45) **Date of Patent:** **Jun. 24, 2025**

(54) **HOUSINGS FOR ELECTRONIC DEVICES**

(71) Applicant: **Hewlett-Packard Development Company, L.P.**, Spring, TX (US)

(72) Inventors: **Chi Hao Chang**, Taipei (TW); **Hendry Huang**, Taipei (TW); **Kuan-Ting Wu**, Taipei (TW)

(73) Assignee: **Hewlett-Packard Development Company, L.P.**, Spring, TX (US)

(\* ) Notice: Subject to any disclaimer, the term of this patent is extended or adjusted under 35 U.S.C. 154(b) by 223 days.

(21) Appl. No.: **18/011,493**

(22) PCT Filed: **Jul. 27, 2020**

(86) PCT No.: **PCT/US2020/043667**

§ 371 (c)(1),

(2) Date: **Dec. 19, 2022**

(87) PCT Pub. No.: **WO2022/025859**

PCT Pub. Date: **Feb. 3, 2022**

(65) **Prior Publication Data**

US 2023/0259179 A1 Aug. 17, 2023

(51) **Int. Cl.**  
**G06F 1/00** (2006.01)  
**G06F 1/16** (2006.01)  
**H01Q 1/22** (2006.01)  
**H01Q 1/40** (2006.01)

(52) **U.S. Cl.**  
CPC ..... **G06F 1/1698** (2013.01); **G06F 1/1656** (2013.01); **H01Q 1/22** (2013.01); **H01Q 1/40** (2013.01)

(58) **Field of Classification Search**

CPC ..... G06F 1/1698; G06F 1/1656; H01Q 1/22; H01Q 1/40

See application file for complete search history.

(56) **References Cited**

U.S. PATENT DOCUMENTS

2004/0178960 A1\* 9/2004 Sun ..... H01Q 1/243  
343/700 MS  
2006/0009251 A1\* 1/2006 Noda ..... H01Q 7/00  
455/550.1  
2006/0152417 A1\* 7/2006 Ying ..... H04M 1/03  
343/702  
2010/0073241 A1\* 3/2010 Ayala Vazquez .... H01Q 1/2266  
343/702  
2010/0073255 A1 3/2010 Noll et al.  
2013/0334168 A1 12/2013 Huang  
2014/0306263 A1 10/2014 Garbar et al.

(Continued)

FOREIGN PATENT DOCUMENTS

EP 1988601 A1\* 11/2008 ..... H01Q 1/40  
JP 2008-028453 A 2/2008  
KR 10-1356356 B1 1/2014

*Primary Examiner* — Pete T Lee

(74) *Attorney, Agent, or Firm* — Shook, Hardy & Bacon L.L.P.

(57) **ABSTRACT**

The present disclosure is drawn to housings for electronic devices. In one example, a housing for an electronic device can include a rigid substrate having an exterior surface including a recessed region positioned at an opening extending through the rigid substrate connecting the recessed region to an interior surface of the rigid substrate. A conductive metal antenna is conformally carried by the recessed region and positioned at the opening.

**18 Claims, 6 Drawing Sheets**

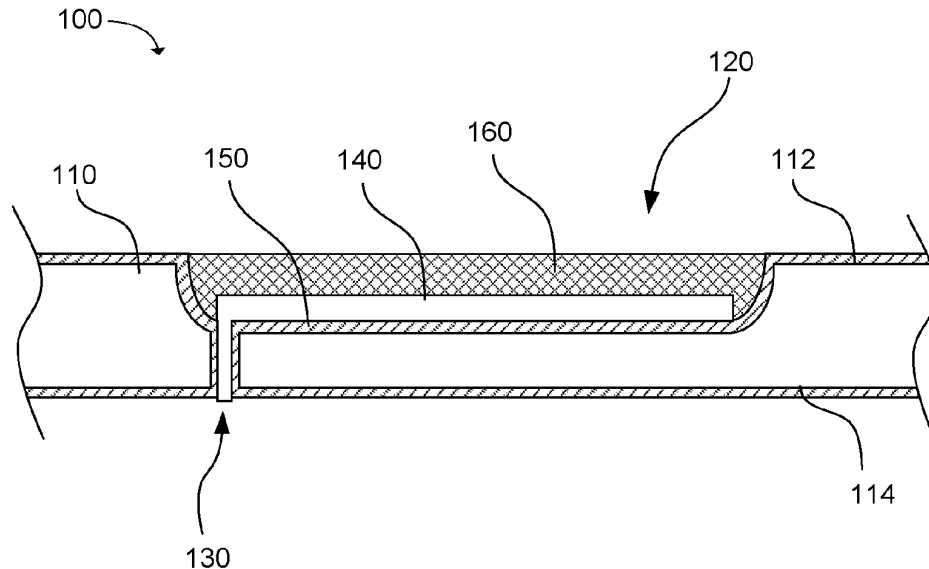



US012341245B2

(12) **United States Patent**  
**Shigihara et al.**

(10) **Patent No.:** **US 12,341,245 B2**  
(45) **Date of Patent:** **Jun. 24, 2025**

(54) **MICROSTRIP ANTENNA**  
(71) Applicant: **Alps Alpine Co., Ltd.**, Tokyo (JP)  
(72) Inventors: **Makoto Shigihara**, Miyagi-ken (JP);  
**Shinji Murata**, Miyagi-ken (JP)  
(73) Assignee: **Alps Alpine Co., Ltd.** (JP)  
(\* ) Notice: Subject to any disclaimer, the term of this patent is extended or adjusted under 35 U.S.C. 154(b) by 194 days.

(21) Appl. No.: **18/344,164**  
(22) Filed: **Jun. 29, 2023**

(65) **Prior Publication Data**  
US 2023/0361474 A1 Nov. 9, 2023

**Related U.S. Application Data**  
(63) Continuation of application No. PCT/JP2021/043546, filed on Nov. 29, 2021.

(30) **Foreign Application Priority Data**  
Feb. 19, 2021 (JP) ..... 2021-025518

(51) **Int. Cl.**  
**H01Q 13/20** (2006.01)  
**H01Q 9/04** (2006.01)  
(52) **U.S. Cl.**  
CPC ..... **H01Q 13/206** (2013.01); **H01Q 9/0407** (2013.01)

(58) **Field of Classification Search**  
CPC ..... H01Q 13/206; H01Q 9/0407; H01Q 1/38; H01Q 13/08  
See application file for complete search history.

(56) **References Cited**  
**U.S. PATENT DOCUMENTS**  
7,583,233 B2 \* 9/2009 Goldberg ..... H01Q 1/287 343/770  
8,912,960 B1 \* 12/2014 Andrenko ..... H01Q 1/38 343/895  
9,768,512 B2 \* 9/2017 Park ..... H01Q 1/48

**FOREIGN PATENT DOCUMENTS**  
CA 2727041 A1 \* 12/2009 ..... G06K 19/07786  
JP S58-215807 A 12/1983  
JP H11-112221 A 4/1999  
JP H11-127014 A 5/1999  
JP 2003-051709 A 2/2003  
KR 20200110069 A \* 9/2020 ..... H01Q 1/48

\* cited by examiner  
*Primary Examiner* — Seung H Lee  
(74) *Attorney, Agent, or Firm* — Harness, Dickey & Pierce, P.L.C.

(57) **ABSTRACT**  
A microstrip antenna includes a dielectric substrate, a ground electrode provided on a first surface of the substrate, an antenna element including a plurality of radiating elements on a second surface of the substrate opposite the first surface so as to extend parallel to one another and a connecting element provided on the second surface to extend in a direction intersecting with the radiating elements and connect the radiating elements, a feed line including a first end portion connected to a portion of the endmost radiating element in plan view, where the portion is located on an extension of the connecting element, and a second end portion provided on a side surface of the substrate between the first and second surfaces to receive power, and a connection line including a section located on the side surface along the feed line and connecting the endmost radiating element to the ground electrode.

**12 Claims, 14 Drawing Sheets**

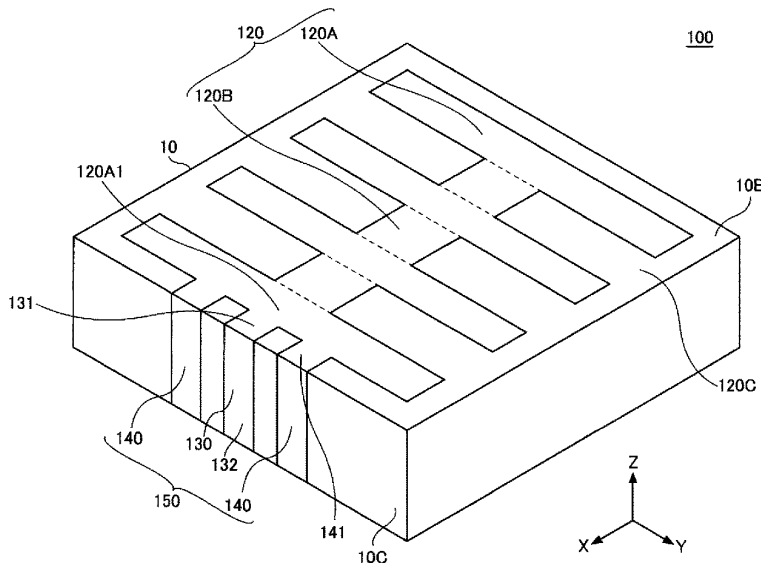



US012341258B2

(12) **United States Patent**  
**Harper et al.**

(10) **Patent No.:** **US 12,341,258 B2**  
(45) **Date of Patent:** **Jun. 24, 2025**

- (54) **COUPLED CHASSIS ANTENNA SYSTEM**
- (71) Applicant: **Microsoft Technology Licensing, LLC**,  
Redmond, WA (US)
- (72) Inventors: **Marc Harper**, Snohomish, WA (US);  
**Nazy Ranjkesh**, Redmond, WA (US)
- (73) Assignee: **Microsoft Technology Licensing, LLC**,  
Redmond, WA (US)
- (\* ) Notice: Subject to any disclaimer, the term of this  
patent is extended or adjusted under 35  
U.S.C. 154(b) by 208 days.

11,233,311	B2	1/2022	Kim et al.	
2019/0199000	A1*	6/2019	Gambahaya .....	H01Q 1/243
2020/0036097	A1	1/2020	Liu	
2021/0167485	A1*	6/2021	So .....	H01Q 1/42
2021/0242566	A1	8/2021	Kim	
2023/0163487	A1*	5/2023	Ma .....	H01Q 9/0421 343/702

(Continued)

**FOREIGN PATENT DOCUMENTS**

CN	112311916	A	*	2/2021
WO	2021188094	A1		9/2021

**OTHER PUBLICATIONS**

International Search Report and Written Opinion received for PCT  
Application No. PCT/US23/035682, Feb. 6, 2024, 15 pages.

(Continued)

- (21) Appl. No.: **18/067,468**
- (22) Filed: **Dec. 16, 2022**
- (65) **Prior Publication Data**  
US 2024/0204406 A1 Jun. 20, 2024

*Primary Examiner* — Dimary S Lopez Cruz  
*Assistant Examiner* — Anna N Hamadyk  
(74) *Attorney, Agent, or Firm* — Holzer Patel Drennan

- (51) **Int. Cl.**  
**H01Q 5/307** (2015.01)  
**H01Q 1/22** (2006.01)  
**H01Q 9/04** (2006.01)
- (52) **U.S. Cl.**  
CPC ..... **H01Q 5/307** (2015.01); **H01Q 1/2266**  
(2013.01); **H01Q 9/0421** (2013.01)
- (58) **Field of Classification Search**  
CPC .... H01Q 5/307; H01Q 1/2266; H01Q 9/0421;  
H01Q 5/378; H01Q 9/0457  
See application file for complete search history.

(57) **ABSTRACT**

A computing device includes a first metal computing device chassis component including an aperture, a second metal computing device chassis component including a display, and a hinge connector mechanically and movably connecting the second metal computing device chassis component to the first metal computing device chassis component. The computing device includes a primary antenna positioned within the first metal computing device chassis component, the primary antenna being configured to radiate radiofrequency signals at a first radiofrequency bandwidth through the aperture in the first metal computing device chassis component and to capacitively couple to the second metal computing device chassis component to radiate radiofrequency signals at a second radiofrequency bandwidth.

- (56) **References Cited**  
U.S. PATENT DOCUMENTS  
7,079,079 B2\* 7/2006 Jo ..... H01Q 9/0442  
343/702  
9,350,068 B2 5/2016 Guterman

**22 Claims, 7 Drawing Sheets**

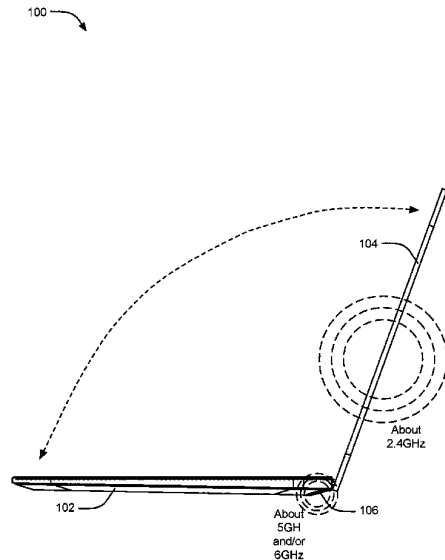



US012341260B2

(12) **United States Patent**  
**Huang et al.**

(10) **Patent No.:** **US 12,341,260 B2**  
(45) **Date of Patent:** **Jun. 24, 2025**

(54) **ANTENNA DEVICE**

(71) Applicant: **PEGATRON CORPORATION**, Taipei (TW)

(72) Inventors: **Chin-Ting Huang**, Taipei (TW); **Hsi-Kai Hung**, Taipei (TW); **Sony Chayadi**, Taipei (TW)

(73) Assignee: **PEGATRON CORPORATION**, Taipei (TW)

(\*) Notice: Subject to any disclaimer, the term of this patent is extended or adjusted under 35 U.S.C. 154(b) by 169 days.

(21) Appl. No.: **18/462,047**

(22) Filed: **Sep. 6, 2023**

(65) **Prior Publication Data**  
US 2024/0128645 A1 Apr. 18, 2024

(30) **Foreign Application Priority Data**  
Oct. 18, 2022 (TW) ..... 111139504

(51) **Int. Cl.**  
**H01Q 1/50** (2006.01)  
**H01Q 5/335** (2015.01)

(52) **U.S. Cl.**  
CPC ..... **H01Q 5/335** (2015.01); **H01Q 1/50** (2013.01)

(58) **Field of Classification Search**  
CPC . H01Q 5/30; H01Q 5/335; H01Q 1/50; G01S 3/14; G01S 3/38; G01S 3/42  
See application file for complete search history.

(56) **References Cited**  
U.S. PATENT DOCUMENTS  
11,239,572 B2\* 2/2022 Hu ..... H01Q 21/28

FOREIGN PATENT DOCUMENTS  
CN 105826654 10/2017  
TW 202130220 8/2021

\* cited by examiner  
*Primary Examiner* — Jimmy T Vu  
(74) *Attorney, Agent, or Firm* — J.C. PATENTS

(57) **ABSTRACT**  
An antenna device includes a body and at least one external antenna. The body includes a processor and a sensor electrically connected to the processor. The processor is configured to receive a sensing signal from the sensor. The external antenna is externally connected to the body at an adjustable angle, and includes a first antenna, a second antenna, and a switch. The switch is electrically connected to the processor, and is switchably electrically connected to the first antenna and the second antenna. When the sensor senses that the external antenna is at a first angle or a second angle relative to the body, the processor switches the switch electrically connected to the first antenna or the second antenna according to the sensing signal, so that the external antenna has a first radiation pattern or a second radiation pattern.

**10 Claims, 6 Drawing Sheets**

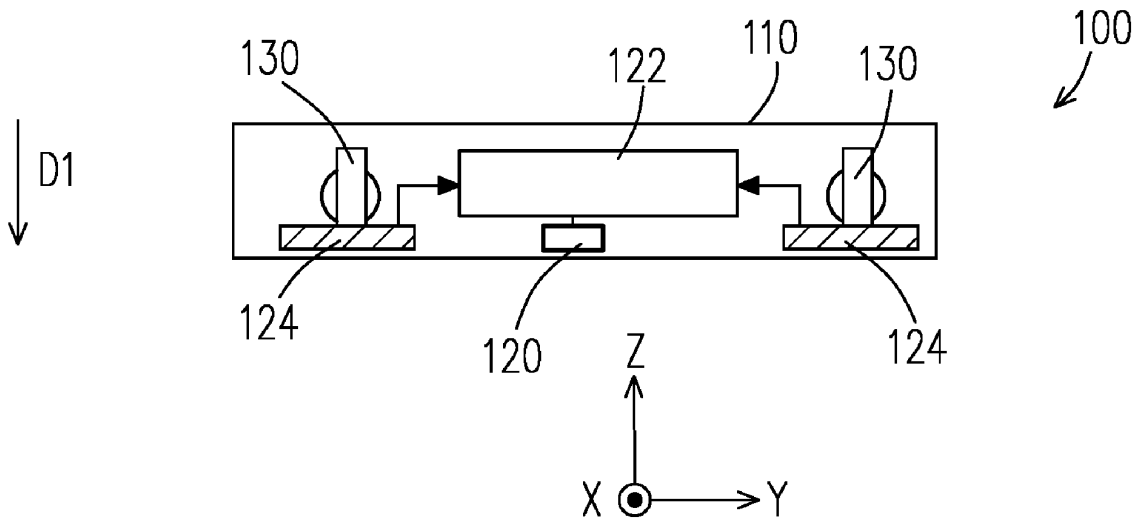





US012341262B2

(12) **United States Patent**  
**Chang**

(10) **Patent No.:** **US 12,341,262 B2**  
(45) **Date of Patent:** **Jun. 24, 2025**

(54) **MOBILE DEVICE FOR REDUCING SPECIFIC ABSORPTION RATE**

(71) Applicant: **Acer Incorporated**, New Taipei (TW)

(72) Inventor: **Kun-Sheng Chang**, New Taipei (TW)

(73) Assignee: **ACER INCORPORATED**, New Taipei (TW)

(\* ) Notice: Subject to any disclaimer, the term of this patent is extended or adjusted under 35 U.S.C. 154(b) by 184 days.

(21) Appl. No.: **18/330,572**

(22) Filed: **Jun. 7, 2023**

(65) **Prior Publication Data**

US 2024/0322430 A1 Sep. 26, 2024

(30) **Foreign Application Priority Data**

Mar. 21, 2023 (TW) ..... 112110337

(51) **Int. Cl.**  
**H01Q 1/48** (2006.01)  
**H01Q 1/52** (2006.01)  
**H01Q 5/40** (2015.01)

(52) **U.S. Cl.**  
CPC ..... **H01Q 5/40** (2015.01); **H01Q 1/48** (2013.01); **H01Q 1/52** (2013.01)

(58) **Field of Classification Search**  
CPC ..... H01Q 1/48; H01Q 1/52; H01Q 1/243; H01Q 1/245; H01Q 1/2266; H01Q 5/40;  
(Continued)

(56) **References Cited**

U.S. PATENT DOCUMENTS

9,136,599 B2 \* 9/2015 Su ..... H01Q 5/357  
9,673,512 B2 6/2017 Lin

(Continued)

FOREIGN PATENT DOCUMENTS

CN 105552532 B 12/2018  
CN 108242589 B 10/2020

(Continued)

OTHER PUBLICATIONS

Chinese language office action dated Mar. 12, 2024, issued in application No. TW 112110337.

*Primary Examiner* — Tung X Le

(74) *Attorney, Agent, or Firm* — McClure, Qualey & Rodack, LLP

(57) **ABSTRACT**

A mobile device for reducing SAR (Specific Absorption Rate) includes a feeding radiation element, a first radiation element, a second radiation element, a grounding radiation element, a first metal element, a second metal element, and a dielectric substrate. The feeding radiation element has a feeding point. The first radiation element is coupled to the feeding radiation element. The second radiation element is coupled to the feeding radiation element. The second radiation element and the first radiation element substantially extend in opposite directions. The grounding radiation element is coupled to the ground voltage. The first metal element is coupled to the grounding radiation element. The second metal element is coupled to the ground voltage. The second metal element is adjacent to the feeding radiation element. An antenna structure is formed by the feeding radiation element, the first radiation element, the second radiation element, and the grounding radiation element.

**14 Claims, 5 Drawing Sheets**

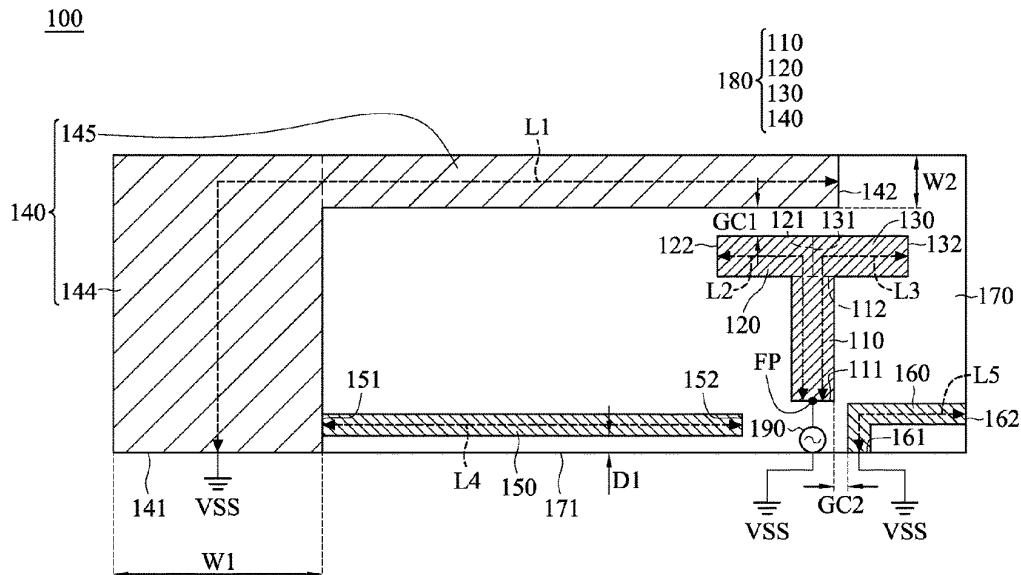



US012341264B2

(12) **United States Patent**  
**Wu et al.**

(10) **Patent No.:** **US 12,341,264 B2**  
(45) **Date of Patent:** **Jun. 24, 2025**

(54) **ANTENNA APPARATUS AND ELECTRONIC DEVICE**

(71) Applicant: **HUAWEI TECHNOLOGIES CO., LTD.**, Shenzhen (CN)

(72) Inventors: **Pengfei Wu**, Shanghai (CN); **Hanyang Wang**, Reading (CN); **Dong Yu**, Shanghai (CN); **Chien-Ming Lee**, Shenzhen (CN); **Liang Xue**, Shanghai (CN)

(73) Assignee: **HUAWEI TECHNOLOGIES CO., LTD.**, Shenzhen (CN)

(\* ) Notice: Subject to any disclaimer, the term of this patent is extended or adjusted under 35 U.S.C. 154(b) by 114 days.

(21) Appl. No.: **18/009,810**

(22) PCT Filed: **Jun. 15, 2021**

(86) PCT No.: **PCT/CN2021/100089**

§ 371 (c)(1),  
(2) Date: **Dec. 12, 2022**

(87) PCT Pub. No.: **WO2021/254322**

PCT Pub. Date: **Dec. 23, 2021**

(65) **Prior Publication Data**

US 2023/0246335 A1 Aug. 3, 2023

(30) **Foreign Application Priority Data**

Jun. 15, 2020 (CN) ..... 202010544996.8

(51) **Int. Cl.**  
**H01Q 5/50** (2015.01)  
**H01Q 1/24** (2006.01)

(Continued)

(52) **U.S. Cl.**  
CPC ..... **H01Q 5/50** (2015.01); **H01Q 1/243** (2013.01); **H01Q 1/521** (2013.01); **H01Q 5/335** (2015.01)

(58) **Field of Classification Search**  
CPC ..... H01Q 1/243; H01Q 1/52; H01Q 5/30-35; H01Q 5/50  
See application file for complete search history.

(56) **References Cited**

U.S. PATENT DOCUMENTS

8,942,761 B2 \* 1/2015 Vance ..... H01Q 9/0421 343/857  
9,379,455 B2 6/2016 Sonnerat et al.  
(Continued)

FOREIGN PATENT DOCUMENTS

CN 105680159 A 6/2016  
CN 108270082 A 7/2018  
(Continued)

*Primary Examiner* — Hasan Islam

(57) **ABSTRACT**

An antenna apparatus and an electronic device. The antenna apparatus includes a feed source, a transmission line, a first radiator including a first feed point, and a second radiator including a second feed point. The transmission line is electrically connected to the feed source. A second end part of the second radiator is disposed away from the first radiator compared to the first end part of the second radiator, a first gap is formed between the first end part of the first radiator and the first end part of the second radiator, the first end part of the first radiator is a ground end, and the first end part of the second radiator is an open end. The two feed points are electrically connected to the transmission line, and the transmission line input a radio frequency signal in a same frequency band to the two feed points.

**20 Claims, 31 Drawing Sheets**

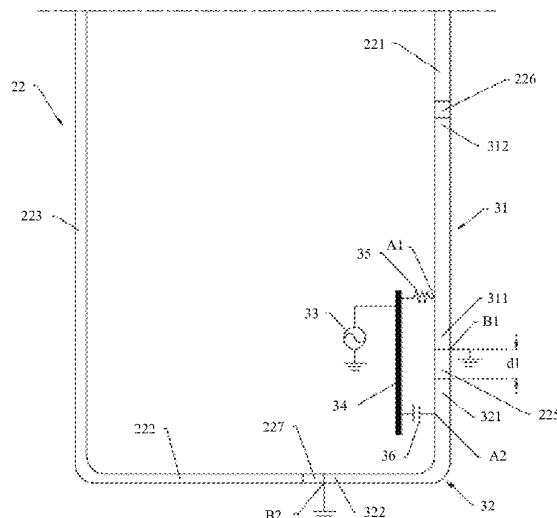



US012341265B2

(12) **United States Patent**  
**Kim et al.**

(10) **Patent No.:** **US 12,341,265 B2**  
(45) **Date of Patent:** **Jun. 24, 2025**

(54) **ELECTRONIC APPARATUS COMPRISING ANTENNA**

(71) Applicant: **SAMSUNG ELECTRONICS CO., LTD.**, Suwon-si (KR)

(72) Inventors: **Sungsoo Kim**, Suwon-si (KR); **Seyoon Bae**, Suwon-si (KR); **Byoungryoul Song**, Suwon-si (KR); **Seungbum Choi**, Suwon-si (KR); **Wonjoon Choi**, Suwon-si (KR); **Joon Heo**, Suwon-si (KR); **Seongjin Park**, Suwon-si (KR); **Sumin Yun**, Suwon-si (KR); **Jaehoon Jo**, Suwon-si (KR); **Woosung Chun**, Suwon-si (KR)

(73) Assignee: **SAMSUNG ELECTRONICS CO., LTD.**, Gyeonggi-Do (KR)

(\* ) Notice: Subject to any disclaimer, the term of this patent is extended or adjusted under 35 U.S.C. 154(b) by 151 days.

(21) Appl. No.: **18/201,382**

(22) Filed: **May 24, 2023**

(65) **Prior Publication Data**  
US 2023/0327337 A1 Oct. 12, 2023

**Related U.S. Application Data**

(63) Continuation of application No. PCT/KR2021/016182, filed on Nov. 9, 2021.

**Foreign Application Priority Data**

Nov. 24, 2020 (KR) ..... 10-2020-0159059

(51) **Int. Cl.**  
**H01Q 1/24** (2006.01)  
**H01Q 9/04** (2006.01)  
**H01Q 21/06** (2006.01)

(52) **U.S. Cl.**  
CPC ..... **H01Q 9/0407** (2013.01); **H01Q 1/241** (2013.01); **H01Q 21/065** (2013.01)

(58) **Field of Classification Search**  
CPC ..... H01Q 1/40; H01Q 1/44; H01Q 1/236; H01Q 1/241; H01Q 1/243; H01Q 9/0407; (Continued)

(56) **References Cited**

**U.S. PATENT DOCUMENTS**

8,395,553 B2 3/2013 Oh  
9,250,613 B2 2/2016 Jenwatanavet et al.  
(Continued)

**FOREIGN PATENT DOCUMENTS**

KR 20070074714 A 7/2007  
KR 20150031065 A 3/2015  
(Continued)

**OTHER PUBLICATIONS**

International Search Report and Written Opinion for International Application No. PCT/KR2021/016182; International Filing Date Nov. 9, 2021; Date of Mailing Mar. 8, 2022; 88 Pages.

(Continued)

*Primary Examiner* — Tung X Le

(74) *Attorney, Agent, or Firm* — CANTOR COLBURN LLP

(57) **ABSTRACT**

An electronic apparatus having a housing, a flexible display, and a key button which is arranged in a first area on a side of a first part is provided. The key button includes at least one protrusion extending toward the inside of the first part and an antenna structure arranged on the inside of the first part with respect to the first area. The housing includes the first part, a second part, and a connection part arranged between the first part and the second part, the second part being rotatably coupled to the first part through the connection part. The antenna structure includes a dome switch

(Continued)

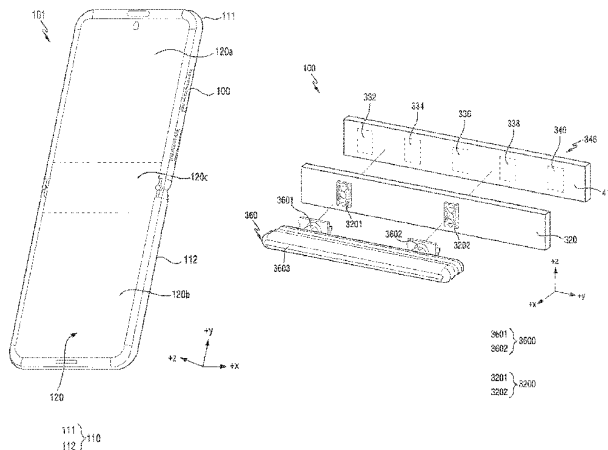



US012341266B2

(12) **United States Patent**  
**Hu et al.**

(10) **Patent No.:** **US 12,341,266 B2**  
(45) **Date of Patent:** **Jun. 24, 2025**

(54) **LOW-SAR ANTENNA AND ELECTRONIC DEVICE**

(58) **Field of Classification Search**  
None

See application file for complete search history.

(71) Applicant: **Honor Device Co., Ltd.**, Shenzhen (CN)

(56) **References Cited**

U.S. PATENT DOCUMENTS

(72) Inventors: **Yiwu Hu**, Shenzhen (CN); **Aofang Zhang**, Shenzhen (CN); **Kunpeng Wei**, Shenzhen (CN)

5,936,587 A 8/1999 Gudilev et al.  
9,439,151 B2 9/2016 Zhu et al.

(Continued)

(73) Assignee: **HONOR DEVICE CO., LTD.**, Shenzhen (CN)

FOREIGN PATENT DOCUMENTS

(\*) Notice: Subject to any disclaimer, the term of this patent is extended or adjusted under 35 U.S.C. 154(b) by 0 days.

CN 201146239 Y 11/2008  
CN 105811103 A 7/2016  
CN 107959106 A 4/2018  
CN 108666741 A 10/2018

(Continued)

(21) Appl. No.: **17/908,153**

OTHER PUBLICATIONS

(22) PCT Filed: **Mar. 30, 2022**

Panchenko, B.A., et al., "Microstrip antennas," Moscow: Radio i svyaz' [Radio and Communication], 1986, 144 pages, with partial translation.

(86) PCT No.: **PCT/CN2022/084112**

§ 371 (c)(1),

(2) Date: **Aug. 30, 2022**

*Primary Examiner* — Dameon E Levi

*Assistant Examiner* — Anh N Ho

(74) *Attorney, Agent, or Firm* — Conley Rose, P.C.

(87) PCT Pub. No.: **WO2022/267600**

PCT Pub. Date: **Dec. 29, 2022**

(57) **ABSTRACT**

(65) **Prior Publication Data**

US 2024/0128646 A1 Apr. 18, 2024

An antenna includes a first radiation structure having a first radiator, and a second radiation structure having a second radiator. A first end of the first radiator and a first end of the second radiator form a first gap. A second end of the first radiator is free, and a second end of the second radiator is grounded. A feed point of the antenna is coupled to the first radiator, and the first radiator is divided into a first portion and a second portion that are delimited by the feed point. In a case that the antenna is in operation, the first portion of the first radiator and the second radiator work together in a first frequency band and a second frequency band, and a frequency of the first frequency band is less than a frequency of the second frequency band.

(30) **Foreign Application Priority Data**

Jun. 25, 2021 (CN) ..... 202110711505.9

**20 Claims, 24 Drawing Sheets**

(51) **Int. Cl.**  
**H01Q 1/48** (2006.01)  
**H01Q 1/24** (2006.01)  
**H01Q 9/04** (2006.01)

(52) **U.S. Cl.**  
CPC ..... **H01Q 9/0421** (2013.01); **H01Q 1/243** (2013.01); **H01Q 1/48** (2013.01)

⊙ Feed point

→ Flowing direction of current

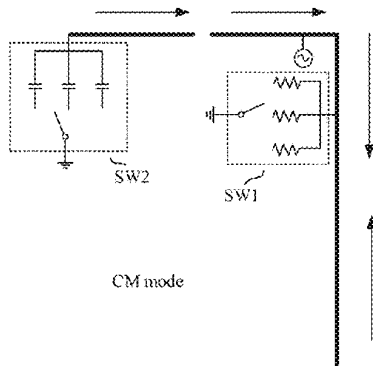

(a)

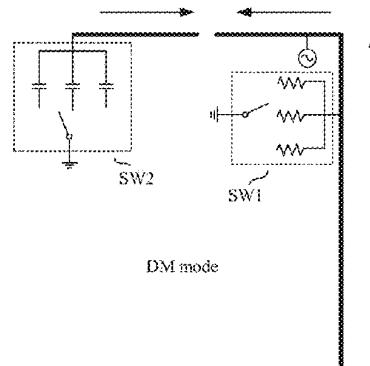

(b)



US012341273B2

(12) **United States Patent**  
**Wu et al.**

(10) **Patent No.:** **US 12,341,273 B2**  
(45) **Date of Patent:** **Jun. 24, 2025**

(54) **ANTENNA UNIT AND COMMUNICATION DEVICE**

(71) Applicant: **HUAWEI TECHNOLOGIES CO., LTD.**, Guangdong (CN)

(72) Inventors: **Pengfei Wu**, Shanghai (CN); **Meng Hou**, Shanghai (CN); **Hanyang Wang**, Reading (GB); **Chien-Ming Lee**, Shenzhen (CN)

(73) Assignee: **Huawei Technologies Co., Ltd.**, Shenzhen (CN)

(\* ) Notice: Subject to any disclaimer, the term of this patent is extended or adjusted under 35 U.S.C. 154(b) by 274 days.

(21) Appl. No.: **18/246,801**

(22) PCT Filed: **Sep. 9, 2021**

(86) PCT No.: **PCT/CN2021/117539**

§ 371 (c)(1),

(2) Date: **Mar. 27, 2023**

(87) PCT Pub. No.: **WO2022/062914**

PCT Pub. Date: **Mar. 31, 2022**

(65) **Prior Publication Data**

US 2023/0369769 A1 Nov. 16, 2023

(30) **Foreign Application Priority Data**

Sep. 28, 2020 (CN) ..... 202011044876.8

(51) **Int. Cl.**

**H01Q 9/42** (2006.01)

**H01Q 21/20** (2006.01)

(52) **U.S. Cl.**

CPC ..... **H01Q 9/42** (2013.01); **H01Q 21/20** (2013.01)

(58) **Field of Classification Search**

CPC ..... H01Q 9/42; H01Q 21/20; H01Q 3/24; H01Q 9/0442; H01Q 9/045; H01Q 1/243; H01Q 1/48

See application file for complete search history.

(56) **References Cited**

U.S. PATENT DOCUMENTS

4,379,296 A 4/1983 Farrar et al.  
2013/0257674 A1 10/2013 Li et al.

(Continued)

FOREIGN PATENT DOCUMENTS

CN 101931856 A 12/2010  
CN 105024134 A 11/2015

(Continued)

OTHER PUBLICATIONS

Behera et al., "Design and Optimization of Dual Band Microstrip Antenna Using Particle Swarm Optimization Technique," Journal of Infrared, Millimeter and Terahertz Waves, Apr. 3, 2010, 10 pages.

(Continued)

*Primary Examiner* — David E Lotter

(74) *Attorney, Agent, or Firm* — Fish & Richardson P.C.

(57) **ABSTRACT**

An antenna includes a first radiator having a first end and a second end, where the second end or a middle position of the first radiator is grounded; a second radiator having a third end and a fourth end, the fourth end is disposed away from the first end relative to the third end, and the second end or a middle position of the second radiator is grounded; a feeding circuit configured to feed the first radiator and the second radiator, at the first end of the first radiator and the third end of the second radiator; and a tuning circuit configured to selectively connect the feeding circuit to the first end of the first radiator or the third end of the second radiator to feed the first radiator or the second radiator.

**20 Claims, 27 Drawing Sheets**

01

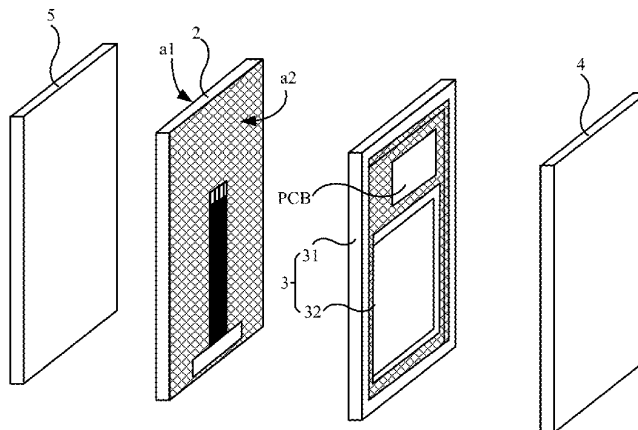



US012341919B2

(12) **United States Patent**  
**Kong et al.**

(10) **Patent No.:** **US 12,341,919 B2**  
(45) **Date of Patent:** **Jun. 24, 2025**

(54) **ANTENNA AND ELECTRONIC DEVICE INCLUDING THE SAME**

(71) Applicant: **Samsung Electronics Co., Ltd.**,  
Suwon-si (KR)

(72) Inventors: **Myeongjun Kong**, Suwon-si (KR);  
**Shinho Yoon**, Suwon-si (KR); **Dongjun Oh**,  
Suwon-si (KR); **Jinwoo Jung**, Suwon-si (KR);  
**Jaebong Chun**, Suwon-si (KR); **Soonho Hwang**,  
Suwon-si (KR)

(73) Assignee: **Samsung Electronics Co., Ltd.**,  
Suwon-si (KR)

(\* ) Notice: Subject to any disclaimer, the term of this  
patent is extended or adjusted under 35  
U.S.C. 154(b) by 409 days.

(21) Appl. No.: **17/716,682**

(22) Filed: **Apr. 8, 2022**

(65) **Prior Publication Data**

US 2022/0321687 A1 Oct. 6, 2022

**Related U.S. Application Data**

(63) Continuation of application No.  
PCT/KR2022/004851, filed on Apr. 5, 2022.

(30) **Foreign Application Priority Data**

Apr. 5, 2021 (KR) ..... 10-2021-0043878

(51) **Int. Cl.**  
**H04M 1/02** (2006.01)  
**H01Q 1/24** (2006.01)

(52) **U.S. Cl.**  
CPC ..... **H04M 1/0277** (2013.01); **H01Q 1/243**  
(2013.01); **H04M 1/0237** (2013.01);  
(Continued)

(58) **Field of Classification Search**  
CPC ..... H04M 1/0277; H04M 1/0237; H04M  
1/0268; H04M 2201/06; H04M 2201/38;  
H01Q 1/243

(Continued)

(56) **References Cited**

U.S. PATENT DOCUMENTS

6,558,192 B1 \* 5/2003 Kuo ..... H01R 13/6335  
439/541.5  
10,936,017 B1 3/2021 Choi et al.  
(Continued)

FOREIGN PATENT DOCUMENTS

CN 110417957 A 11/2019  
JP 4413145 B2 2/2010  
(Continued)

OTHER PUBLICATIONS

International Search Report and written opinion dated Jul. 11, 2022,  
in International Application No. PCT/KR2022/004851.

(Continued)

*Primary Examiner* — Jean A Gelin

(74) *Attorney, Agent, or Firm* — Jefferson IP Law, LLP

(57) **ABSTRACT**

An electronic device is provided. The electronic device includes a first housing including a first space and a conductive portion formed through at least a portion of a first side member, a second housing slidably coupled to the first housing in a first direction, at least partially overlapped with the first side member in a slide-in state, and including a second side member including a second space, a flexible display disposed to receive support from the first housing and the second housing and in which a display area at least partially varies when the electronic device is changed from the slide-in state to a slide-out state, a wireless communication circuit disposed in the first space and configured to transmit or receive a wireless signal in at least one frequency

(Continued)

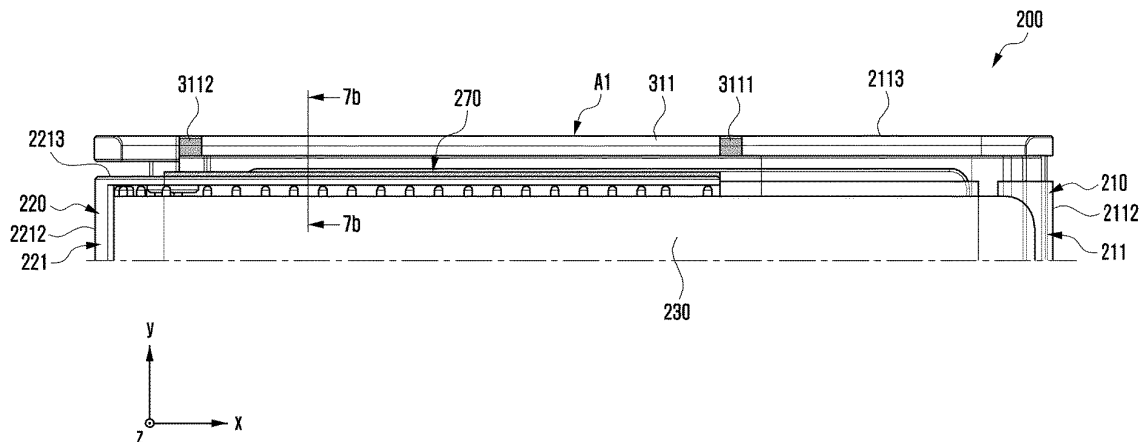



US012347922B2

(12) **United States Patent**  
**Son et al.**

(10) **Patent No.:** **US 12,347,922 B2**

(45) **Date of Patent:** **Jul. 1, 2025**

(54) **ELECTRONIC DEVICE COMPRISING ANTENNA**

(58) **Field of Classification Search**

CPC ..... H01Q 1/243; H01Q 1/38; H01Q 7/00; H01Q 1/01-38; H04M 1/0216; H04M 1/0277

(71) Applicant: **Samsung Electronics Co., Ltd.**, Suwon-si (KR)

(Continued)

(72) Inventors: **Cheolhong Son**, Suwon-si (KR); **Sangha Lee**, Suwon-si (KR); **Soonho Hwang**, Suwon-si (KR); **Sungjun Lee**, Suwon-si (KR); **Hyunjeong Lee**, Suwon-si (KR)

(56) **References Cited**

U.S. PATENT DOCUMENTS

9,667,296 B2 5/2017 Kim et al.  
10,230,154 B2 3/2019 Jeon et al.

(Continued)

(73) Assignee: **Samsung Electronics Co., Ltd.**, Suwon-si (KR)

FOREIGN PATENT DOCUMENTS

(\* ) Notice: Subject to any disclaimer, the term of this patent is extended or adjusted under 35 U.S.C. 154(b) by 379 days.

KR 10-2016-0027700 A 3/2016  
KR 10-2017-0066944 A 6/2017

(Continued)

(21) Appl. No.: **17/885,012**

OTHER PUBLICATIONS

(22) Filed: **Aug. 10, 2022**

Korean Office Action dated Dec. 23, 2024, issued in Korean Application No. 10-2020-0148691.

(65) **Prior Publication Data**  
US 2022/0384934 A1 Dec. 1, 2022

Primary Examiner — Jean A Gelin

(74) Attorney, Agent, or Firm — Jefferson IP Law, LLP

**Related U.S. Application Data**

(63) Continuation of application No. PCT/KR2021/001125, filed on Jan. 28, 2021.

(57) **ABSTRACT**

An electronic device comprising an antenna is provided. The electronic device includes a lateral member forming at least one region of the lateral surface of the electronic device, the lateral member including a first conductive portion, a second conductive portion, and a first non-conductive portion, a printed circuit board connected to one end of the second conductive portion, which is adjacent to the first conductive portion, and including a first region and a ground, the first region including a conductive layer, and a wireless communication circuit disposed on the printed circuit board. The conductive layer of the first region may be electrically connected to the ground, the first conductive portion may receive power from the wireless communication circuit at a first point and be grounded via the printed circuit board at a second point, and the second conductive portion may receive power from the wireless communication circuit.

(30) **Foreign Application Priority Data**

Feb. 10, 2020 (KR) ..... 10-2020-0015647  
Nov. 9, 2020 (KR) ..... 10-2020-0148691

(51) **Int. Cl.**  
**H01Q 1/38** (2006.01)  
**H01Q 1/24** (2006.01)

(Continued)

(52) **U.S. Cl.**  
CPC ..... **H01Q 1/243** (2013.01); **H01Q 1/38** (2013.01); **H01Q 7/00** (2013.01); **H04M 1/0216** (2013.01); **H04M 1/0277** (2013.01)

**15 Claims, 26 Drawing Sheets**

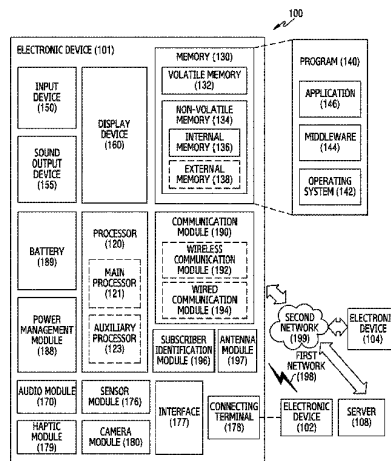



US012347929B2

(12) **United States Patent**  
**Pourghorban Saghati et al.**

(10) **Patent No.:** **US 12,347,929 B2**  
(45) **Date of Patent:** **Jul. 1, 2025**

- (54) **ANTENNA FEED STRUCTURE** 2014/0035097 A1\* 2/2014 Lin ..... H01L 23/66  
257/E29.325
- (71) Applicant: **Apple Inc.**, Cupertino, CA (US) 2015/0270618 A1\* 9/2015 Zhu ..... H01Q 1/243  
343/702
- (72) Inventors: **Alireza Pourghorban Saghati**, San Jose, CA (US); **Jerzy S Guterman**, Sunnyvale, CA (US); **Jue Wang**, San Jose, CA (US) 2019/0252757 A1\* 8/2019 Baek ..... H01Q 1/243  
2019/0334231 A1\* 10/2019 Sakurai ..... H01L 23/66  
2020/0021010 A1\* 1/2020 Ou ..... H01Q 21/065  
2020/0052367 A1 2/2020 Zhu et al.  
2020/0052368 A1 2/2020 Xia et al.  
2020/0381833 A1\* 12/2020 Giancesello ..... H01Q 21/28  
2023/0014567 A1\* 1/2023 Yeon ..... H01Q 13/10  
2023/0163487 A1\* 5/2023 Ma ..... H01Q 9/0421  
343/702
- (73) Assignee: **Apple Inc.**, Cupertino, CA (US)
- (\* ) Notice: Subject to any disclaimer, the term of this patent is extended or adjusted under 35 U.S.C. 154(b) by 214 days.

**OTHER PUBLICATIONS**

- (21) Appl. No.: **17/886,678** U.S. Appl. No. 17/380,491, filed Jul. 20, 2021.
- (22) Filed: **Aug. 12, 2022** \* cited by examiner

(65) **Prior Publication Data**

US 2024/0055768 A1 Feb. 15, 2024

- (51) **Int. Cl.**  
**H01Q 13/10** (2006.01)  
**H01Q 9/04** (2006.01)
- (52) **U.S. Cl.**  
CPC ..... **H01Q 13/10** (2013.01); **H01Q 9/045** (2013.01)

*Primary Examiner* — Dimary S Lopez Cruz  
*Assistant Examiner* — Anna N Hamadyk  
(74) *Attorney, Agent, or Firm* — Treyz Law Group, P.C.; Tianyi He

(57) **ABSTRACT**

An electronic device may include one or more radios and one or more antennas. Radio-frequency transmission lines may couple a radio to an antenna feed structure. The antenna feed structure may be wireless coupled to one or more antenna resonating elements. An intervening slot element may be disposed between the antenna feed structure and the one or more antenna resonating elements. The antenna feed structure may be disposed on a package substrate forming an integrated circuit package. The one or more antenna resonating elements may be disposed on an antenna support structure. The integrated circuit package and the antenna support structure may be mounted to the same side or opposing sides of a system substrate.

- (58) **Field of Classification Search**  
CPC ..... H01Q 13/10; H01Q 9/045; H01Q 1/2283; H01Q 9/0457; H01Q 13/206; H01Q 13/16; H01Q 1/243; H01Q 9/0414; H01Q 1/50; H01Q 1/22; H01Q 1/36; H01Q 21/0006; H01L 23/3121; H04B 1/40  
See application file for complete search history.

(56) **References Cited**

**U.S. PATENT DOCUMENTS**

- 10,193,222 B2\* 1/2019 Mizunuma ..... H01Q 1/526
- 2013/0015563 A1\* 1/2013 Lee ..... H01Q 9/0414  
257/659

**17 Claims, 7 Drawing Sheets**

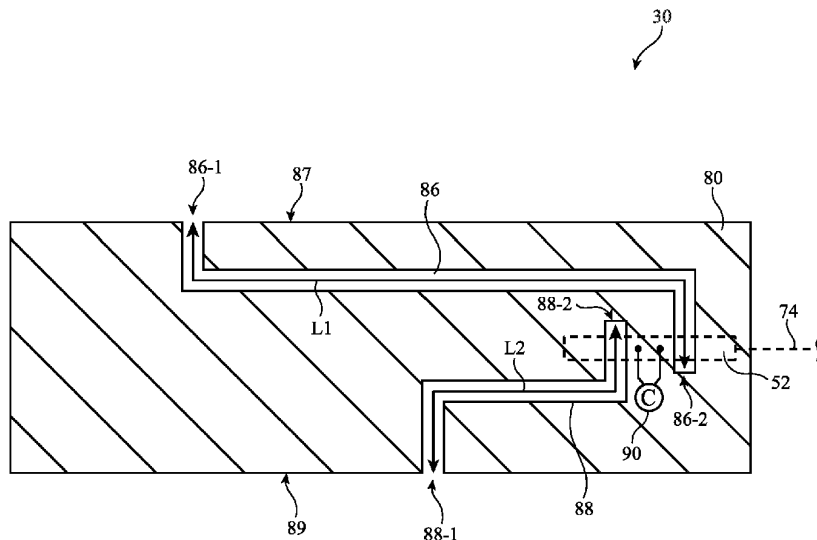



US012347932B2

(12) **United States Patent**  
**Seo et al.**

(10) **Patent No.:** **US 12,347,932 B2**  
(45) **Date of Patent:** **Jul. 1, 2025**

(54) **DUAL POLARIZATION ANTENNA AND ELECTRONIC DEVICE INCLUDING SAME**

(58) **Field of Classification Search**  
None  
See application file for complete search history.

(71) Applicant: **Samsung Electronics Co., Ltd.**,  
Gyeonggi-do (KR)

(56) **References Cited**

(72) Inventors: **Seunghan Seo**, Gyeonggi-do (KR);  
**Jaehoon Song**, Gyeonggi-do (KR);  
**Yunbum Lee**, Gyeonggi-do (KR);  
**Janghoon Han**, Gyeonggi-do (KR);  
**Dongil Son**, Gyeonggi-do (KR)

U.S. PATENT DOCUMENTS

6,320,542 B1 11/2001 Yamamoto et al.  
7,834,803 B2 11/2010 Weinstein  
(Continued)

(73) Assignee: **Samsung Electronics Co., Ltd.**,  
Suwon-si (KR)

FOREIGN PATENT DOCUMENTS

CN 111313153 A 6/2020  
JP 06-326508 A 11/1994  
(Continued)

(\* ) Notice: Subject to any disclaimer, the term of this patent is extended or adjusted under 35 U.S.C. 154(b) by 186 days.

OTHER PUBLICATIONS

European Search Report dated Oct. 16, 2023.  
Korean Office Action dated Feb. 1, 2025.

(21) Appl. No.: **18/093,060**

*Primary Examiner* — Jany Richardson

(22) Filed: **Jan. 4, 2023**

(74) *Attorney, Agent, or Firm* — Cha & Reiter, LLC.

(65) **Prior Publication Data**

US 2023/0145636 A1 May 11, 2023

(57) **ABSTRACT**

**Related U.S. Application Data**

(63) Continuation of application No. PCT/KR2021/006549, filed on May 26, 2021.

A disclosed electronic device includes a wireless communication circuit and a plurality of antenna elements. Each of the plurality of antenna elements may include: a first feeder arranged at a first point on a first virtual line, a second feeder arranged at a second point on a second virtual line perpendicular to the first virtual line, and a third feeder arranged at a third point on a third virtual line. The first, second, and third feeders may be connected to the wireless communication unit via first, second, and third electrical paths, respectively. The device may further include a switch arranged on the first electrical path, the second electrical path, and the third electrical path, and configured to electrically connect or disconnect the first feeder, the second feeder, and the third feeder to the wireless communication circuit.

(30) **Foreign Application Priority Data**

Jul. 7, 2020 (KR) ..... 10-2020-0083451

(51) **Int. Cl.**  
**H01Q 21/24** (2006.01)  
**H01Q 1/24** (2006.01)  
**H01Q 9/04** (2006.01)

(52) **U.S. Cl.**  
CPC ..... **H01Q 21/24** (2013.01); **H01Q 1/243** (2013.01); **H01Q 9/045** (2013.01)

**19 Claims, 37 Drawing Sheets**

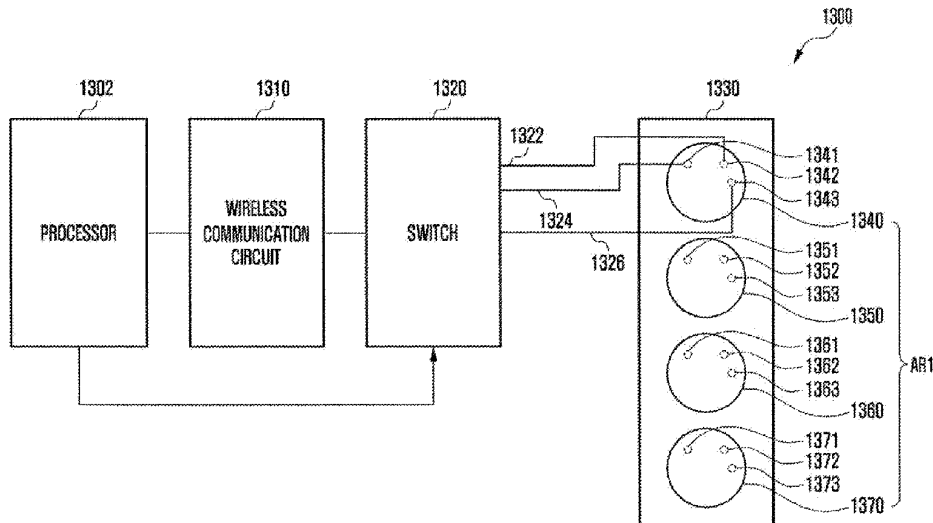



US012347943B2

(12) **United States Patent**  
**Tsuchiya et al.**

(10) **Patent No.:** **US 12,347,943 B2**  
(45) **Date of Patent:** **Jul. 1, 2025**

(54) **MULTIBAND ANTENNA**  
(71) Applicant: **JAPAN AVIATION ELECTRONICS INDUSTRY, LIMITED**, Tokyo (JP)  
(72) Inventors: **Kenta Tsuchiya**, Tokyo (JP); **Hiroshi Toyao**, Tokyo (JP)  
(73) Assignee: **JAPAN AVIATION ELECTRONICS INDUSTRY, LIMITED**, Tokyo (JP)  
(\* ) Notice: Subject to any disclaimer, the term of this patent is extended or adjusted under 35 U.S.C. 154(b) by 91 days.

(56) **References Cited**  
U.S. PATENT DOCUMENTS  
9,196,952 B2 11/2015 Tran et al.  
2004/0140938 A1 7/2004 Kadambi et al.  
(Continued)  
FOREIGN PATENT DOCUMENTS  
JP 2012085262 A 4/2012  
JP 2012182632 A 9/2012  
(Continued)

(21) Appl. No.: **17/719,505**  
(22) Filed: **Apr. 13, 2022**  
(65) **Prior Publication Data**  
US 2022/0376400 A1 Nov. 24, 2022

**OTHER PUBLICATIONS**  
Korean Office Action (and an English language translation thereof) dated Jul. 29, 2023, issued in counterpart Korean Application No. 10-2022-0045746.  
(Continued)

(30) **Foreign Application Priority Data**  
May 19, 2021 (JP) ..... 2021-084571

*Primary Examiner* — Robert Karacsony  
(74) *Attorney, Agent, or Firm* — Holtz, Holtz & Volek PC

(51) **Int. Cl.**  
**H01Q 5/364** (2015.01)  
**H01Q 1/36** (2006.01)  
**H01Q 13/10** (2006.01)  
(52) **U.S. Cl.**  
CPC ..... **H01Q 5/364** (2015.01); **H01Q 1/36** (2013.01); **H01Q 13/10** (2013.01)

(57) **ABSTRACT**  
A multiband antenna is connected to a host conductor when used. The multiband antenna extends long in a first direction. The multiband antenna has a conductor main portion and a ground terminal. The conductor main portion extends in a horizontal plane which is defined by the first direction and a second direction perpendicular to the first direction. The conductor main portion is formed with an opening and a slot. The slot extends long in the first direction. The conductor main portion has a first short edge, a second short edge, a first long edge and a second long edge. The ground terminal is connected to the host conductor when the multiband antenna is used. The ground terminal extends from the second long edge. The ground terminal is positioned closer to the first short edge than to the second short edge in the first direction.

(58) **Field of Classification Search**  
CPC ..... H01Q 1/2258; H01Q 1/2266; H01Q 1/36; H01Q 1/38; H01Q 1/243; H01Q 5/342;  
(Continued)

**10 Claims, 9 Drawing Sheets**

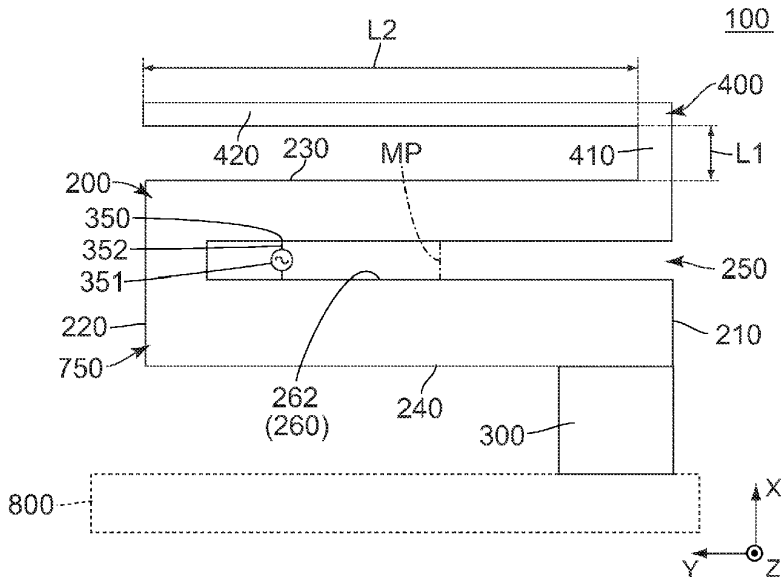



US012347945B2

(12) **United States Patent**  
**Kakuya et al.**

(10) **Patent No.:** **US 12,347,945 B2**  
(45) **Date of Patent:** **Jul. 1, 2025**

(54) **WIRELESS COMMUNICATION DEVICE**  
(71) Applicant: **DENSO CORPORATION**, Kariya (JP)  
(72) Inventors: **Yuuji Kakuya**, Nisshin (JP); **Masakazu Ikeda**, Nisshin (JP); **Kenichiro Sanji**, Kariya (JP); **Tomokazu Miyashita**, Kariya (JP); **Ryozo Fujii**, Kariya (JP); **Masashi Urabe**, Kariya (JP); **Hiroimichi Naito**, Kariya (JP)  
(73) Assignee: **DENSO CORPORATION**, Kariya (JP)  
(\* ) Notice: Subject to any disclaimer, the term of this patent is extended or adjusted under 35 U.S.C. 154(b) by 199 days.

(21) Appl. No.: **18/338,191**

(22) Filed: **Jun. 20, 2023**

(65) **Prior Publication Data**  
US 2023/0335907 A1 Oct. 19, 2023

**Related U.S. Application Data**  
(63) Continuation of application No. PCT/JP2021/046687, filed on Dec. 17, 2021.

(30) **Foreign Application Priority Data**  
Dec. 23, 2020 (JP) ..... 2020-213995

(51) **Int. Cl.**  
**H01Q 9/04** (2006.01)  
**H01Q 1/32** (2006.01)

(52) **U.S. Cl.**  
CPC ..... **H01Q 9/0407** (2013.01); **H01Q 1/3283** (2013.01)

(58) **Field of Classification Search**  
CPC ..... H01Q 1/24; H01Q 1/32; H01Q 1/3283; H01Q 9/0407  
See application file for complete search history.

(56) **References Cited**  
U.S. PATENT DOCUMENTS  
2010/0289619 A1 11/2010 Kosugi et al.  
2013/0225102 A1\* 8/2013 Tsutsumi ..... H01Q 23/00 257/E31.11

(Continued)

FOREIGN PATENT DOCUMENTS  
JP 5341611 B2 11/2013  
JP 2018061137 A 4/2018  
*Primary Examiner* — Daniel Munoz  
(74) *Attorney, Agent, or Firm* — Harness, Dickey & Pierce, P.L.C.

(57) **ABSTRACT**  
A wireless communication device for transmitting and receiving radio waves of a target frequency includes a ground plate having a rectangular shape, a zeroth-order resonant antenna element arranged at a position shifted from a center of the ground plate in a lengthwise direction of the ground plate, and a circuit module configured to transmit and receive signal via the zeroth-order resonant antenna element. The zeroth-order resonant antenna element includes a counter conductor plate arranged at a predetermined distance from the ground plate and having a feed point connected to a feedline, and a short circuit portion electrically connecting the counter conductor plate and the ground plate. The ground plate, the counter conductor plate and the short circuit portion are configured to cause parallel resonance at the target frequency and satisfy a condition that resonance caused by the ground plate is reduced.

**6 Claims, 8 Drawing Sheets**

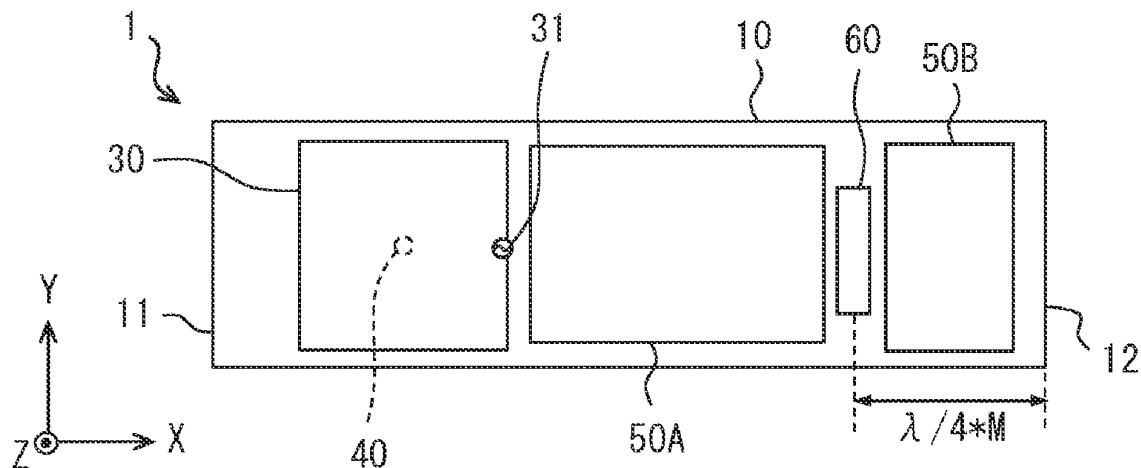



US012354078B1

(12) **United States Patent**  
**Bidari et al.**

(10) **Patent No.:** **US 12,354,078 B1**  
(45) **Date of Patent:** **Jul. 8, 2025**

(54) **SYSTEMS AND METHODS FOR COMMUNICATING WITH NFC READERS**

(71) Applicant: **Block, Inc.**, Oakland, CA (US)

(72) Inventors: **Emad Bidari**, Toronto (CA); **Mani Razaghi Kashani**, Palo Alto, CA (US); **Anthony Newpower**, Edwards, CO (US); **Abdullah Yeaser**, San Francisco, CA (US)

(73) Assignee: **Block, Inc.**, Oakland, CA (US)

(\* ) Notice: Subject to any disclaimer, the term of this patent is extended or adjusted under 35 U.S.C. 154(b) by 378 days.

(21) Appl. No.: **18/092,021**

(22) Filed: **Dec. 30, 2022**

(51) **Int. Cl.**  
**G06Q 20/32** (2012.01)  
**H01Q 1/22** (2006.01)

(52) **U.S. Cl.**  
CPC ..... **G06Q 20/3278** (2013.01); **H01Q 1/2216** (2013.01)

(58) **Field of Classification Search**  
CPC ..... G06Q 20/3278; H01Q 1/2216  
See application file for complete search history.

(56) **References Cited**

U.S. PATENT DOCUMENTS

11,012,119 B2\* 5/2021 Liu ..... H04B 5/266  
2008/0302875 A1\* 12/2008 Chien ..... G06K 7/0013  
235/492  
2010/0093412 A1\* 4/2010 Serra ..... H04M 1/7246  
455/575.8

2010/0182764 A1\* 7/2010 Phillips ..... H05K 9/002  
361/816  
2012/0068908 A1\* 3/2012 Lee ..... H01Q 1/40  
343/873  
2012/0122520 A1\* 5/2012 Phillips ..... H04M 1/21  
455/556.2  
2012/0206302 A1\* 8/2012 Ramachandran ..... H01Q 1/22  
343/866  
2014/0128132 A1\* 5/2014 Cox, III ..... H04M 1/185  
455/575.8  
2014/0268519 A1\* 9/2014 Huang ..... H04B 1/3888  
361/679.01  
2014/0300518 A1\* 10/2014 Ramachandran ..... H01Q 5/371  
343/702

(Continued)

FOREIGN PATENT DOCUMENTS

CN 101043222 A \* 9/2007 ..... G06K 7/10178  
CN 103595828 A \* 2/2014

(Continued)

Primary Examiner — Ashford S Hayles

(74) Attorney, Agent, or Firm — Polsinelli PC

(57) **ABSTRACT**

A mobile NFC payment reader, such as a smartphone or tablet, has a casing for protecting the reader from damage. The casing also includes circuitry having at least two NFC antennas that are electrically coupled to each other and capable of wireless communication with an NFC antenna of the reader. One of the casing's antennas is positioned such that it is aligned with and close to the reader's antenna. The other antenna of the casing may be positioned at another location relatively far from the reader's antenna, thereby extending the range at which a payment device can communicate with the reader's antenna. Thus, a tap location for the reader may be established at a more convenient or intuitive location, as may be desired, without having to change the location of the reader's antenna.

20 Claims, 7 Drawing Sheets

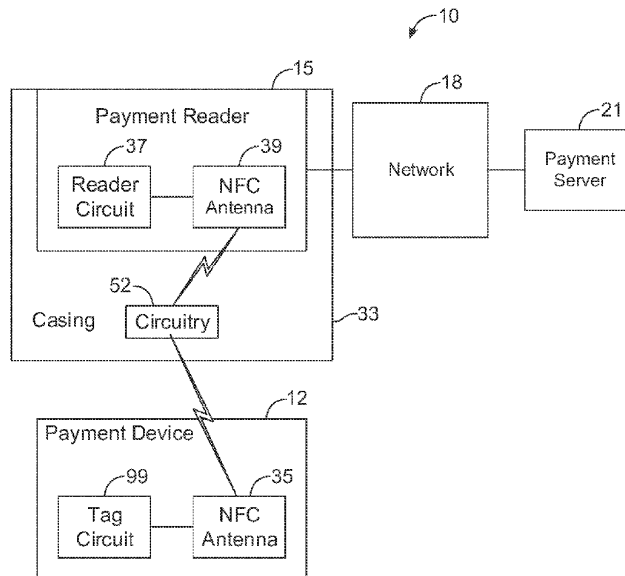



US012355136B2

(12) **United States Patent**  
**Kim et al.**

(10) **Patent No.:** **US 12,355,136 B2**  
(45) **Date of Patent:** **Jul. 8, 2025**

(54) **SYSTEM AND METHOD FOR AN EMBEDDED FLEXIBLE SHEET ANTENNA FOR NARROW BORDER DISPLAY**

(58) **Field of Classification Search**  
CPC ..... H01Q 1/2266; H01Q 1/42  
See application file for complete search history.

(71) Applicant: **Dell Products, LP**, Round Rock, TX (US)

(56) **References Cited**

U.S. PATENT DOCUMENTS

(72) Inventors: **Changsoo Kim**, Cedar Park, TX (US);  
**Jay M. Zill**, Round Rock, TX (US);  
**Anthony J. Sanchez**, Pflugerville, TX (US);  
**Sumana Pallampati**, Austin, TX (US)

2012/0223866 A1\* 9/2012 Ayala Vazquez ..... H01Q 21/28  
343/893  
2013/0321216 A1\* 12/2013 Jervis ..... H04M 1/0216  
343/702  
2017/0373376 A1\* 12/2017 Jo ..... H01Q 1/50  
2020/0104667 A1\* 4/2020 Boyer ..... G06K 19/07336  
2021/0296766 A1\* 9/2021 Li ..... H04M 1/026

(73) Assignee: **DELL PRODUCTS LP**, Round Rock, TX (US)

\* cited by examiner

(\* ) Notice: Subject to any disclaimer, the term of this patent is extended or adjusted under 35 U.S.C. 154(b) by 323 days.

*Primary Examiner* — Dimary S Lopez Cruz  
*Assistant Examiner* — Austin M Back  
(74) *Attorney, Agent, or Firm* — Prol Intellectual Property Law, PLLC; H. Kenneth Prol Prol

(21) Appl. No.: **17/731,806**

(57) **ABSTRACT**

(22) Filed: **Apr. 28, 2022**

An information handling system may include a processor, a memory, a power management unit, an antenna controller to provide instructions to a radio to cause a flexible sheet antenna to transceive wirelessly with a network, where the flexible sheet antenna has an antenna structure formed on a flexible sheet circuit, and an antenna holder around which the flexible sheet antenna is wrapped, wherein the flexible sheet antenna and antenna holder are placed within an edge cavity portion of a display chassis sharing the edge cavity with one or more interfacing hook structures used to couple a first chassis cover portion of the display chassis to a second chassis cover portion of the display chassis.

(65) **Prior Publication Data**

US 2023/0352809 A1 Nov. 2, 2023

(51) **Int. Cl.**  
**H01Q 1/22** (2006.01)  
**H01Q 1/24** (2006.01)  
**H01Q 9/04** (2006.01)  
**H04M 1/02** (2006.01)

(52) **U.S. Cl.**  
CPC ..... **H01Q 1/2266** (2013.01); **H01Q 1/243** (2013.01); **H01Q 9/0421** (2013.01); **H04M 1/0266** (2013.01)

**20 Claims, 9 Drawing Sheets**

300

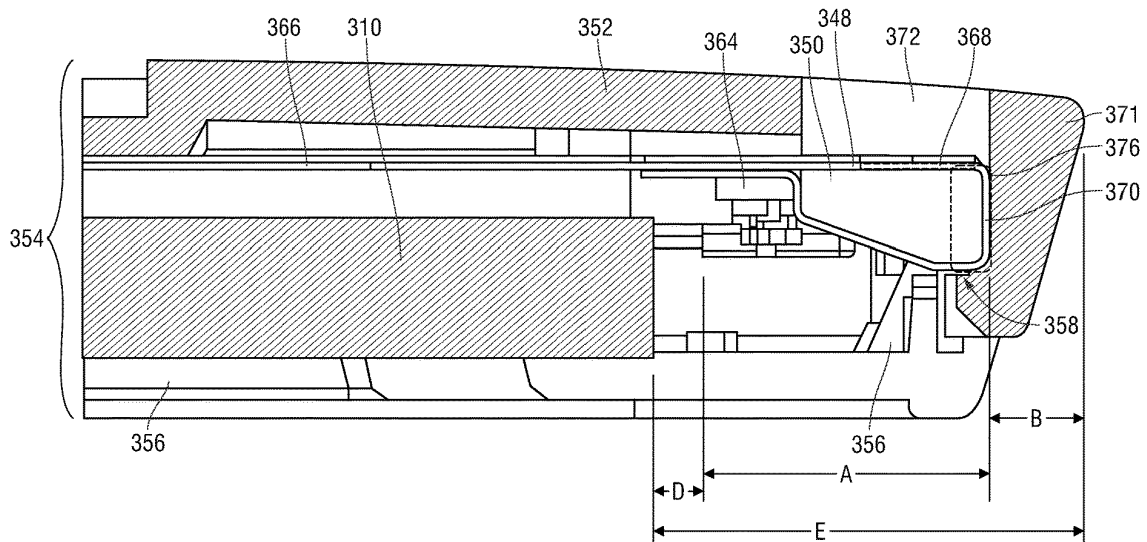



US012355143B2

(12) **United States Patent**  
**Huang et al.**

(10) **Patent No.:** **US 12,355,143 B2**  
(45) **Date of Patent:** **Jul. 8, 2025**

- (54) **SIGNAL SENSING DEVICE**
- (71) Applicant: **METAL INDUSTRIES RESEARCH & DEVELOPMENT CENTRE**, Kaohsiung (TW)
- (72) Inventors: **Shu-Hung Huang**, Kaohsiung (TW); **Chun-Chieh Tseng**, Kaohsiung (TW); **Jui-Han Lu**, Kaohsiung (TW); **Chun-Ming Chen**, Kaohsiung (TW); **Ping-Ruey Chou**, New Taipei (TW); **Yen-Hsin Kuo**, Kaohsiung (TW); **Tung-Lin Tsai**, Tainan (TW); **Yen-Hao Chang**, Kaohsiung (TW); **Sheng-Hua Wu**, Kaohsiung (TW); **Chia-Hua Chang**, Changhua County (TW); **Wen-Ming Cheng**, Kaohsiung (TW)
- (73) Assignee: **METAL INDUSTRIES RESEARCH & DEVELOPMENT CENTRE**, Kaohsiung (TW)
- (\* ) Notice: Subject to any disclaimer, the term of this patent is extended or adjusted under 35 U.S.C. 154(b) by 140 days.

(21) Appl. No.: **18/498,606**

(22) Filed: **Oct. 31, 2023**

(65) **Prior Publication Data**  
US 2025/0141091 A1 May 1, 2025

- (51) **Int. Cl.**  
**H01Q 1/27** (2006.01)  
**A61B 5/00** (2006.01)  
(Continued)
- (52) **U.S. Cl.**  
CPC ..... **H01Q 1/273** (2013.01); **A61B 5/026** (2013.01); **A61B 5/07** (2013.01); **A61B 5/6876** (2013.01)

(58) **Field of Classification Search**  
CPC ..... H01Q 1/273; A61B 5/07; A61B 5/026; A61B 5/6876  
See application file for complete search history.

- (56) **References Cited**  
U.S. PATENT DOCUMENTS  
5,929,825 A \* 7/1999 Niu ..... H01Q 9/0442 343/866  
8,761,896 B2 \* 6/2014 Vajha ..... H01Q 9/0414 607/32

(Continued)

FOREIGN PATENT DOCUMENTS

JP 2014504903 A 2/2014  
JP 2021137138 A 9/2021  
(Continued)

*Primary Examiner* — Ab Salam Alkassim, Jr.  
(74) *Attorney, Agent, or Firm* — WPAT, PC

(57) **ABSTRACT**  
A signal sensing device includes a body and two signal sensing elements disposed in the body. An insulating layer is sandwiched between the two signal sensing elements. Each of the two signal sensing elements includes a signal transmission section and a signal sensing section in electrical connection with the signal transmission section. The signal transmission sections are planar antennae parallel to each other and each having an antenna shape of meander-line type. The antenna shape of each transmission section has a vertical projection on a plane parallel to each signal transmission section. The vertical projections of the antenna shapes do not overlap completely. When a portion of the body forms a surrounding portion which surrounds a to-be-sensed target, a portion or an entirety of each signal sensing section is located on the surrounding portion.

**13 Claims, 8 Drawing Sheets**

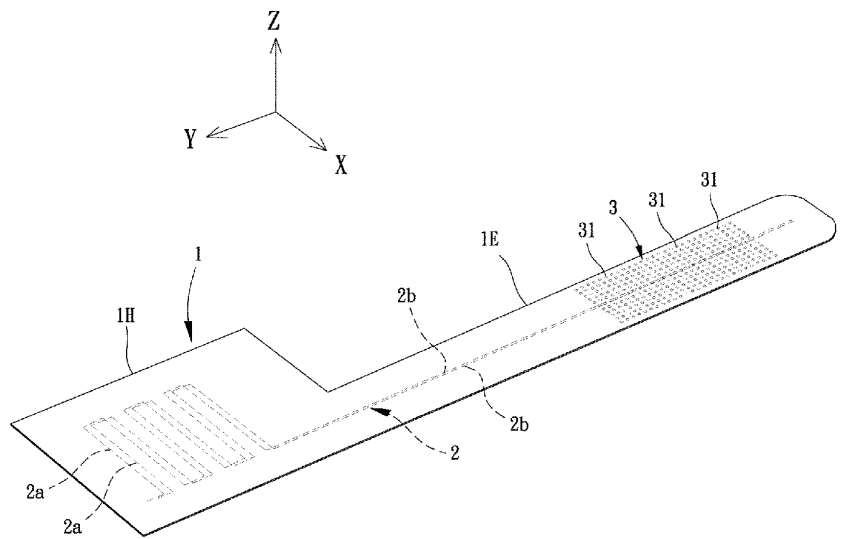



US012355152B2

(12) **United States Patent**  
**Sowpati et al.**

(10) **Patent No.:** **US 12,355,152 B2**  
(45) **Date of Patent:** **Jul. 8, 2025**

(54) **CAVITY-BACKED SLOT ANTENNA AND ELECTRONIC DEVICE COMPRISING THE SLOT ANTENNA**

(58) **Field of Classification Search**  
CPC ..... H01Q 1/24; H01Q 13/18; H01Q 1/243; H01Q 1/2266  
See application file for complete search history.

(71) Applicants: **Arun Sowpati**, Kista (SE); **Huawei Technologies Co., Ltd.**, Shenzhen (CN)

(56) **References Cited**

(72) Inventors: **Arun Sowpati**, Kista (SE); **Antti Karilainen**, Kista (SE); **Joonas Krogerus**, Helsinki (FI); **Zlatoljub Milosavljevic**, Helsinki (FI)

U.S. PATENT DOCUMENTS

6,618,020 B2 9/2003 Wang et al.  
6,636,183 B1 10/2003 Hellgren et al.  
8,077,096 B2 12/2011 Chiang et al.  
8,373,601 B2 2/2013 Wu et al.

(Continued)

(73) Assignee: **HUAWEI TECHNOLOGIES CO., LTD.**, Shenzhen (CN)

FOREIGN PATENT DOCUMENTS

(\*) Notice: Subject to any disclaimer, the term of this patent is extended or adjusted under 35 U.S.C. 154(b) by 112 days.

EP 0989627 A1 3/2000  
WO 2019120515 A1 6/2019

(Continued)

(21) Appl. No.: **17/770,222**

OTHER PUBLICATIONS

(22) PCT Filed: **Oct. 22, 2019**

Sumin Yun, et al., "Bandwidth Enhancement of Cavity-Backed Slot Antenna Using a via-Hole above the Slot," IEEE Antennas and Wireless Propagation Letters, vol. 11, 2012, 4 pages.

(86) PCT No.: **PCT/EP2019/078639**

§ 371 (c)(1),

(2) Date: **Apr. 19, 2022**

*Primary Examiner* — Dimary S Lopez Cruz

*Assistant Examiner* — Aladdin Abdulkaki

(74) *Attorney, Agent, or Firm* — Conley Rose, P.C.

(87) PCT Pub. No.: **WO2021/078365**

PCT Pub. Date: **Apr. 29, 2021**

(57) **ABSTRACT**

A cavity-backed slot antenna for an electronic device comprises a first conductive structure and a second conductive structure. A dielectric slot extends between the first conductive structure and the second conductive structure. A third conductive structure extends from the first conductive structure and is juxtaposed with the dielectric slot. A dielectric volume is partially enclosed by the first conductive structure, the second conductive structure, and the third conductive structure, and the dielectric volume comprises the dielectric slot.

(65) **Prior Publication Data**

US 2022/0399650 A1 Dec. 15, 2022

(51) **Int. Cl.**  
**H01Q 13/18** (2006.01)  
**H01Q 1/24** (2006.01)

(52) **U.S. Cl.**  
CPC ..... **H01Q 13/18** (2013.01); **H01Q 1/243** (2013.01)

**21 Claims, 4 Drawing Sheets**

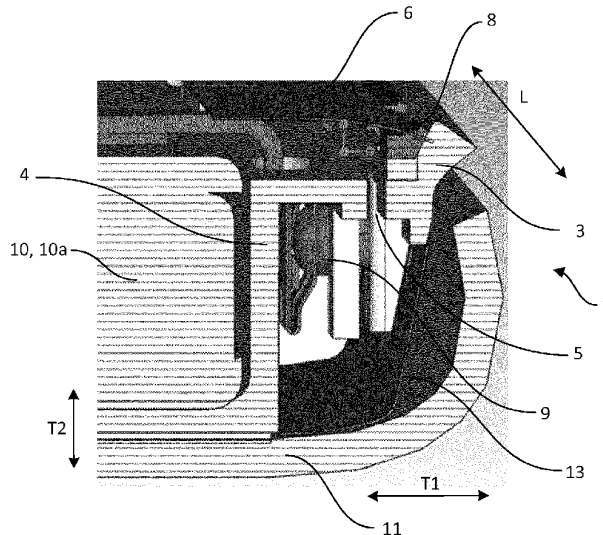



US012355161B2

(12) **United States Patent**  
**Shen**

(10) **Patent No.:** **US 12,355,161 B2**  
(45) **Date of Patent:** **Jul. 8, 2025**

(54) **ANTENNA INTERFERENCE PREVENTION METHOD, COMMUNICATION DEVICE AND STORAGE MEDIUM**

(71) Applicant: **ZTE CORPORATION**, Shenzhen (CN)

(72) Inventor: **Shaowu Shen**, Shenzhen (CN)

(73) Assignee: **ZTE CORPORATION**, Shenzhen (CN)

(\*) Notice: Subject to any disclaimer, the term of this patent is extended or adjusted under 35 U.S.C. 154(b) by 216 days.

(21) Appl. No.: **18/247,146**

(22) PCT Filed: **Aug. 5, 2021**

(86) PCT No.: **PCT/CN2021/110923**

§ 371 (c)(1),  
(2) Date: **Mar. 29, 2023**

(87) PCT Pub. No.: **WO2022/078031**

PCT Pub. Date: **Apr. 21, 2022**

(65) **Prior Publication Data**

US 2023/0369757 A1 Nov. 16, 2023

(30) **Foreign Application Priority Data**

Oct. 13, 2020 (CN) ..... 202011090081.0

(51) **Int. Cl.**  
**H01Q 3/02** (2006.01)  
**G01R 29/08** (2006.01)

(Continued)

(52) **U.S. Cl.**  
CPC ..... **H01Q 3/02** (2013.01); **G01R 29/0892** (2013.01); **H01Q 1/2266** (2013.01); **H01Q 1/523** (2013.01)

(58) **Field of Classification Search**

USPC ..... 343/702  
See application file for complete search history.

(56) **References Cited**

U.S. PATENT DOCUMENTS

8,792,444 B2 \* 7/2014 Ishida ..... H01Q 1/246 455/562.1

10,498,029 B1 \* 12/2019 Tran ..... F21V 33/0052  
(Continued)

FOREIGN PATENT DOCUMENTS

CN 107611612 A 1/2018  
CN 110035149 A \* 7/2019 ..... H04B 7/0404  
(Continued)

OTHER PUBLICATIONS

European Patent Office. Partial Supplementary European Search Report for EP Application No. 21879078.0, mailed Jan. 26, 2024, pp. 1-11.

(Continued)

*Primary Examiner* — Dimary S Lopez Cruz

*Assistant Examiner* — Brandon Sean Woods

(74) *Attorney, Agent, or Firm* — Vivacqua Crane, PLLC

(57) **ABSTRACT**

Disclosed are an antenna anti-interference method, a communication device, and a storage medium. The antenna anti-interference method may include: detecting performance parameters of a single antenna and a combination of antennas in an antenna sequence group of a communication device, the antenna sequence group comprises a group of antennas simultaneously operating in different antenna roles, and corresponding antenna sequence groups are different in response to any one of the antennas or the antenna roles being different; determining, according to the performance parameters, an antenna to be adjusted from the antenna sequence group; adjusting the antenna to be adjusted to reduce interference on the antenna sequence group; and controlling operation of an adjusted antenna sequence group.

**10 Claims, 5 Drawing Sheets**

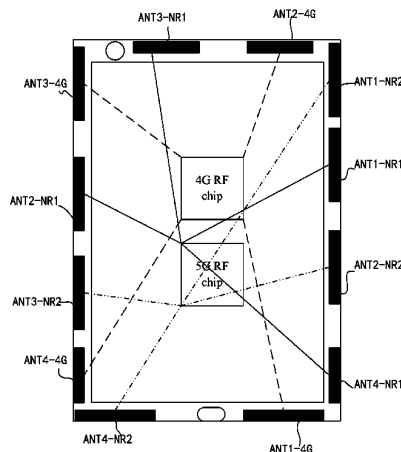



US012355163B2

(12) **United States Patent**  
**Wu et al.**

(10) **Patent No.:** **US 12,355,163 B2**  
(45) **Date of Patent:** **Jul. 8, 2025**

(54) **ELECTRONIC DEVICE WITH MULTIPLE ANTENNA MODES**

(71) Applicant: **HUAWEI TECHNOLOGIES CO., LTD.**, Guangdong (CN)

(72) Inventors: **Pengfei Wu**, Shanghai (CN); **Hanyang Wang**, Reading (GB); **Kun Feng**, Shanghai (CN); **Dong Yu**, Shanghai (CN); **Meng Hou**, Shanghai (CN)

(73) Assignee: **HUAWEI TECHNOLOGIES CO., LTD.**, Shenzhen (CN)

(\*) Notice: Subject to any disclaimer, the term of this patent is extended or adjusted under 35 U.S.C. 154(b) by 291 days.

(21) Appl. No.: **17/802,900**

(22) PCT Filed: **Jan. 25, 2021**

(86) PCT No.: **PCT/CN2021/073626**

§ 371 (c)(1),

(2) Date: **Aug. 26, 2022**

(87) PCT Pub. No.: **WO2021/169700**

PCT Pub. Date: **Sep. 2, 2021**

(65) **Prior Publication Data**

US 2023/0146114 A1 May 11, 2023

(30) **Foreign Application Priority Data**

Feb. 29, 2020 (CN) ..... 202010132991.4

(51) **Int. Cl.**  
**H01Q 5/40** (2015.01)  
**H01Q 1/24** (2006.01)

(Continued)

(52) **U.S. Cl.**

CPC ..... **H01Q 5/40** (2015.01); **H01Q 1/243** (2013.01); **H01Q 5/10** (2015.01); **H01Q 5/307** (2015.01);

(Continued)

(58) **Field of Classification Search**

CPC ..... H01Q 5/40; H01Q 1/243; H01Q 5/10; H01Q 5/307; H01Q 5/35; H01Q 13/106;

(Continued)

(56) **References Cited**

**U.S. PATENT DOCUMENTS**

8,164,537 B2\* 4/2012 Kinezos ..... H01Q 1/243 343/702

8,686,918 B1 4/2014 Diaz  
(Continued)

**FOREIGN PATENT DOCUMENTS**

AU 2018426062 A1 1/2020

CN 105742812 A 7/2016

(Continued)

**OTHER PUBLICATIONS**

Geng Yanfeng, Design of Diffirential Dual-Feqency Filting-Antenna, Aug. 2017 ,6 pages.

*Primary Examiner* — Hai V Tran

(74) *Attorney, Agent, or Firm* — WOMBLE BOND DICKINSON (US) LLP

(57) **ABSTRACT**

An antenna structure including a slot antenna and a wire antenna is disposed, and the antenna structure is excited to generate four antenna modes: a common mode slot antenna, a differential mode slot antenna, a common mode wire antenna, and a differential mode wire antenna in a symmetric feed manner and an anti-symmetric feed manner.

**17 Claims, 26 Drawing Sheets**

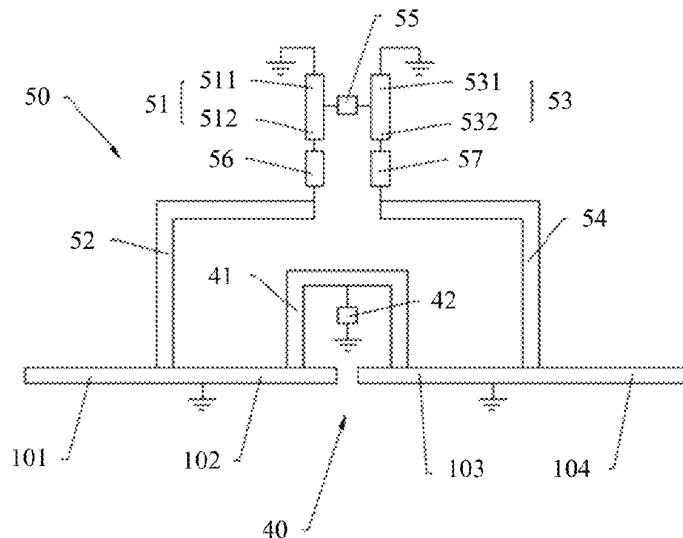



US012355165B2

(12) **United States Patent**  
**Wu et al.**

(10) **Patent No.:** **US 12,355,165 B2**  
(45) **Date of Patent:** **Jul. 8, 2025**

(54) **ELECTRONIC DEVICE**

(71) Applicant: **PEGATRON CORPORATION**, Taipei (TW)

(72) Inventors: **Chien-Yi Wu**, Taipei (TW); **Chih-Wei Liao**, Taipei (TW); **Chao-Hsu Wu**, Taipei (TW); **Hau Yuen Tan**, Taipei (TW); **Shih-Keng Huang**, Taipei (TW); **Cheng-Hsiung Wu**, Taipei (TW); **Chia-Hung Chen**, Taipei (TW); **Sheng-Chin Hsu**, Taipei (TW); **Hao-Hsiang Yang**, Taipei (TW)

(73) Assignee: **PEGATRON CORPORATION**, Taipei (TW)

(\* ) Notice: Subject to any disclaimer, the term of this patent is extended or adjusted under 35 U.S.C. 154(b) by 251 days.

(21) Appl. No.: **18/317,862**

(22) Filed: **May 15, 2023**

(65) **Prior Publication Data**

US 2024/0006769 A1 Jan. 4, 2024

(30) **Foreign Application Priority Data**

Jul. 4, 2022 (TW) ..... 111124879

(51) **Int. Cl.**

**H01Q 9/04** (2006.01)  
**H01Q 1/12** (2006.01)  
**H01Q 1/24** (2006.01)  
**H01Q 5/371** (2015.01)  
**H01Q 21/28** (2006.01)

(52) **U.S. Cl.**

CPC ..... **H01Q 9/0407** (2013.01); **H01Q 1/12** (2013.01); **H01Q 1/243** (2013.01); **H01Q 5/371** (2015.01); **H01Q 9/04** (2013.01); **H01Q 21/28** (2013.01)

(58) **Field of Classification Search**

CPC ..... H01Q 9/0407; H01Q 1/12; H01Q 5/371; H01Q 1/243; H01Q 21/28; H01Q 9/04  
See application file for complete search history.

(56) **References Cited**

U.S. PATENT DOCUMENTS

10,559,882 B2 2/2020 Lee et al.  
2018/0006364 A1\* 1/2018 Wu ..... H01Q 5/30  
2018/0331415 A1\* 11/2018 Wu ..... H01Q 1/2266  
(Continued)

FOREIGN PATENT DOCUMENTS

CN 104466390 3/2015  
CN 104701619 6/2015  
TW 200514303 4/2005

Primary Examiner — Hai V Tran

(74) *Attorney, Agent, or Firm* — J.C. PATENTS

(57) **ABSTRACT**

An electronic device including a metal bottom plate, a metal frame and at least one radiator is provided. The metal bottom plate includes at least one ground terminal. The metal frame includes at least one slot, at least one disconnecting part, at least one first connecting part and at least one second connecting part. The disconnecting part includes a first part and a second part. Each radiator includes a first terminal and a second terminal. The second terminal is connected to a junction between the first part and the second part. The first terminal, the second terminal, the first part, the first connecting part and the ground terminal form a first antenna path radiating at a first frequency band. The first terminal, the second terminal, the second part, the second connecting part and the ground terminal form a second antenna path radiating at a second frequency band.

10 Claims, 8 Drawing Sheets

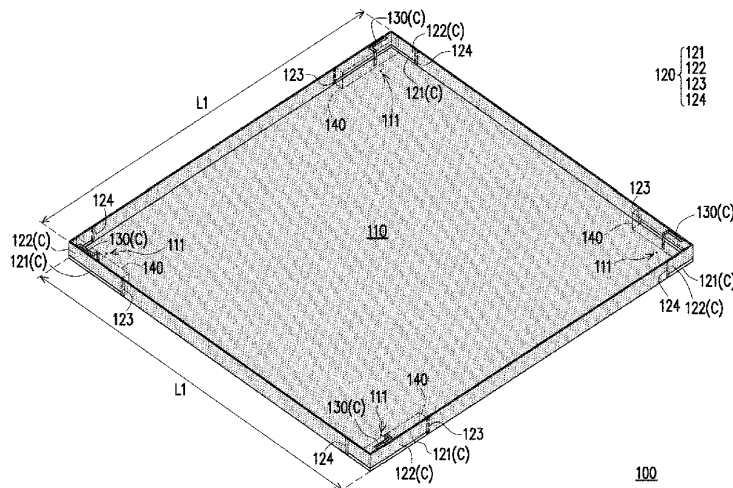



US012362458B2

(12) **United States Patent**  
**Yun et al.**

(10) **Patent No.:** **US 12,362,458 B2**  
(45) **Date of Patent:** **Jul. 15, 2025**

(54) **ELECTRONIC DEVICE INCLUDING SLOT ANTENNA**

(71) Applicant: **Samsung Electronics Co., Ltd.**,  
Gyeonggi-do (KR)

(72) Inventors: **Sumin Yun**, Gyeonggi-do (KR);  
**Kyunggu Kim**, Gyeonggi-do (KR);  
**Kyungmoon Seol**, Gyeonggi-do (KR);  
**Kyihyun Jang**, Gyeonggi-do (KR);  
**Jaebong Chun**, Gyeonggi-do (KR)

(73) Assignee: **Samsung Electronics Co., Ltd.** (KR)

(\*) Notice: Subject to any disclaimer, the term of this patent is extended or adjusted under 35 U.S.C. 154(b) by 214 days.

(21) Appl. No.: **18/083,813**

(22) Filed: **Dec. 19, 2022**

(65) **Prior Publication Data**

US 2023/0118903 A1 Apr. 20, 2023

**Related U.S. Application Data**

(63) Continuation of application No. PCT/KR2021/016563, filed on Nov. 12, 2021.

(30) **Foreign Application Priority Data**

Nov. 13, 2020 (KR) ..... 10-2020-0152073  
Dec. 14, 2020 (KR) ..... 10-2020-0174767

(51) **Int. Cl.**  
**H01Q 1/24** (2006.01)  
**H01Q 13/10** (2006.01)

(52) **U.S. Cl.**  
CPC ..... **H01Q 1/243** (2013.01); **H01Q 13/106** (2013.01)

(58) **Field of Classification Search**  
USPC ..... 343/702  
See application file for complete search history.

(56) **References Cited**

U.S. PATENT DOCUMENTS

8,654,030 B1 2/2014 Mercer  
10,075,569 B2 9/2018 Kim et al.  
(Continued)

FOREIGN PATENT DOCUMENTS

KR 10-2014-0105886 9/2014  
KR 10-2017-0050270 5/2017  
(Continued)

OTHER PUBLICATIONS

European Search Report dated Feb. 13, 2024 issued in counterpart application No. 21892372.0-1205, 8 pages.

(Continued)

*Primary Examiner* — Hoang V Nguyen  
*Assistant Examiner* — Brandon Sean Woods  
(74) *Attorney, Agent, or Firm* — The Farrell Law Firm, P.C.

(57) **ABSTRACT**

An electronic device is provided that includes a first housing including a first conductive region with a first slot structure that extends to a first edge of the first housing. The electronic device also includes a second housing movable with respect to the first housing and including a second conductive region with a second slot structure that extends to a second edge of the second housing. The electronic device also includes a wireless communication circuit that feeds power to a point on the first slot structure. The wireless communication circuit receives a first signal on a first electrical path including the first slot structure while the first edge and the second edge are spaced apart from each other, and receives a second signal on a second electrical path including the first slot structure and the second slot structure while the first edge is in contact with the second edge.

**20 Claims, 26 Drawing Sheets**

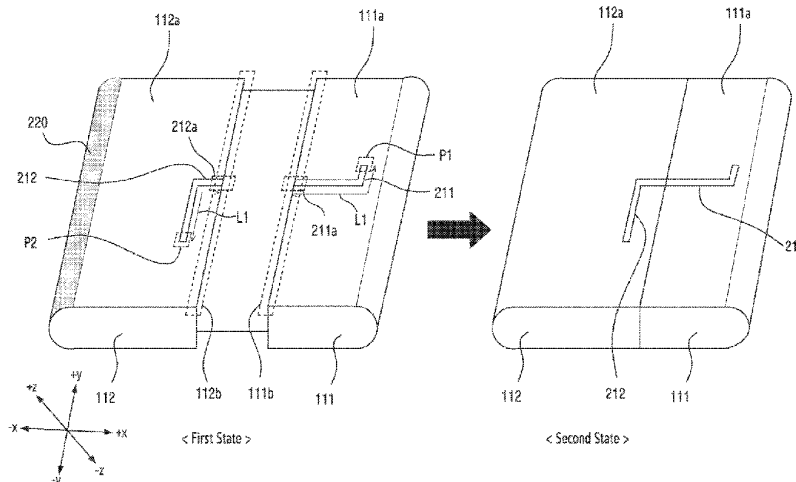



US012362459B2

(12) **United States Patent**  
**Yoon et al.**

(10) **Patent No.:** **US 12,362,459 B2**  
(45) **Date of Patent:** **Jul. 15, 2025**

(54) **ELECTRONIC DEVICE COMPRISING ANTENNA**

(71) Applicant: **Samsung Electronics Co., Ltd.**,  
Suwon-si (KR)

(72) Inventors: **Shinho Yoon**, Suwon-si (KR);  
**Myeongjun Kong**, Suwon-si (KR);  
**Dongjun Oh**, Suwon-si (KR);  
**Seunghwan Kim**, Suwon-si (KR);  
**Soonho Hwang**, Suwon-si (KR)

(73) Assignee: **Samsung Electronics Co., Ltd.**,  
Suwon-si (KR)

(\* ) Notice: Subject to any disclaimer, the term of this patent is extended or adjusted under 35 U.S.C. 154(b) by 229 days.

(21) Appl. No.: **18/168,898**

(22) Filed: **Feb. 14, 2023**

(65) **Prior Publication Data**  
US 2023/0198130 A1 Jun. 22, 2023

**Related U.S. Application Data**

(63) Continuation of application No. PCT/KR2022/012428, filed on Aug. 19, 2022.

(30) **Foreign Application Priority Data**

Aug. 20, 2021 (KR) ..... 10-2021-0110209

(51) **Int. Cl.**  
**H01Q 1/24** (2006.01)  
**H01Q 1/48** (2006.01)  
(Continued)

(52) **U.S. Cl.**  
CPC ..... **H01Q 1/243** (2013.01); **H01Q 1/48** (2013.01); **H01Q 5/307** (2015.01); **H01Q 13/106** (2013.01)

(58) **Field of Classification Search**  
CPC ..... H01Q 1/243; H01Q 1/48; H01Q 13/106;  
H01Q 13/10; H01Q 1/38; H01Q 5/35;  
H01Q 5/307; H04M 1/026  
See application file for complete search history.

(56) **References Cited**

U.S. PATENT DOCUMENTS

10,629,982 B2 4/2020 Kim et al.  
10,776,187 B2 9/2020 Sharifi et al.  
(Continued)

FOREIGN PATENT DOCUMENTS

CN 108281763 A 7/2018  
EP 3035441 A1 \* 6/2016 ..... H01Q 1/243  
(Continued)

OTHER PUBLICATIONS

Shu-Chuan Chen et al., LTE MIMO Closed Slot Antenna System for Laptops with a Metal Cover, Mar. 1, 2019, IEEE, vol. 7 (Year: 2019).\*

(Continued)

*Primary Examiner* — Graham P Smith

(74) *Attorney, Agent, or Firm* — Jefferson IP Law, LLP

(57) **ABSTRACT**

An electronic device is provided. The electronic device includes a first conductive frame, a second conductive frame, a split portion, a conductive structure disposed inside the electronic device, a first conductive member, and a wireless communication circuit electrically connected to the first conductive frame, the second conductive member, a conductive portion, and the first conductive member, and the second conductive member, wherein the wireless communication circuit may be configured to transmit and/or receive a radio signal by using at least a portion of an electric path provided by the first conductive frame, the first conductive member, the second conductive member, the conductive portion, and the conductive structure by feeding power to the

(Continued)

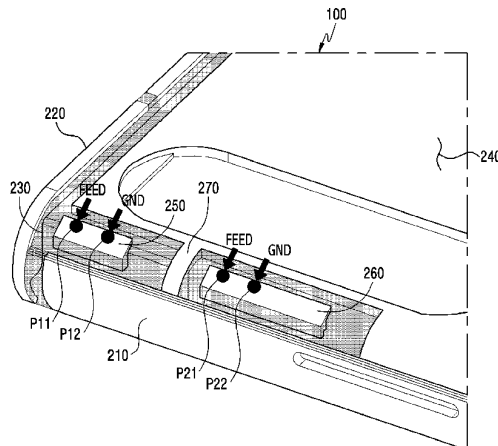



US012362460B2

(12) **United States Patent**  
**Wilson et al.**

(10) **Patent No.:** **US 12,362,460 B2**  
(45) **Date of Patent:** **Jul. 15, 2025**

(54) **LENSED MULTIPLE BAND MULTIPLE BEAM MULTIPLE COLUMN DUAL-POLARIZED ANTENNA**

(71) Applicants: **Matsing, Inc.**, Irvine, CA (US); **APG Technologies, Inc.**, Orange, CA (US)

(72) Inventors: **John Stewart Wilson**, Huntington Beach, CA (US); **Igor Timofeev**, Dallas, TX (US)

(73) Assignee: **Matsing, Inc.**, Irvine, CA (US)

(\*) Notice: Subject to any disclaimer, the term of this patent is extended or adjusted under 35 U.S.C. 154(b) by 0 days.

(21) Appl. No.: **17/334,225**

(22) Filed: **May 28, 2021**

(65) **Prior Publication Data**  
US 2022/0384935 A1 Dec. 1, 2022

(51) **Int. Cl.**  
**H01Q 1/24** (2006.01)  
**H01Q 3/46** (2006.01)  
**H01Q 5/30** (2015.01)  
**H01Q 19/10** (2006.01)  
**H01Q 25/00** (2006.01)

(52) **U.S. Cl.**  
CPC ..... **H01Q 1/246** (2013.01); **H01Q 3/46** (2013.01); **H01Q 5/30** (2015.01); **H01Q 19/104** (2013.01); **H01Q 25/001** (2013.01)

(58) **Field of Classification Search**  
CPC ..... H01Q 1/246; H01Q 3/46; H01Q 5/30; H01Q 19/104; H01Q 25/001  
See application file for complete search history.

(56) **References Cited**

U.S. PATENT DOCUMENTS

7,079,083 B2 7/2006 Gottl et al.  
7,405,710 B2 7/2008 Bisiules et al.  
7,605,768 B2 10/2009 Ebling et al.  
8,199,063 B2 6/2012 Moon et al.  
8,482,478 B2 7/2013 Hartenstein  
9,843,108 B2 12/2017 Le et al.  
10,381,716 B2 8/2019 Matitsine et al.

(Continued)

FOREIGN PATENT DOCUMENTS

WO WO-2010/092078 A2 8/2010  
WO WO-2014/118011 A1 8/2014

(Continued)

OTHER PUBLICATIONS

International Search Report and Written Opinion dated Sep. 16, 2022 for International Application No. PCT/US2022/031386, 10 pgs.

(Continued)

*Primary Examiner* — Graham P Smith

*Assistant Examiner* — Amal Patel

(74) *Attorney, Agent, or Firm* — Fish IP Law, LLP

(57) **ABSTRACT**

The inventive subject matter provides apparatus, systems and methods in which a high port count base station antenna uses an array of spherical lenses with multiple ports per frequency band, containing multiple frequency bands, and capable of multiple beam operation. In a preferred embodiment, the antenna system comprises a plurality of spherical, dielectric lenses, stacked vertically, where each lens is surrounded by four or more lower frequency radiating elements, or one circular element. The circular element can have multiple sub-elements, along with feed gaps.

**18 Claims, 13 Drawing Sheets**

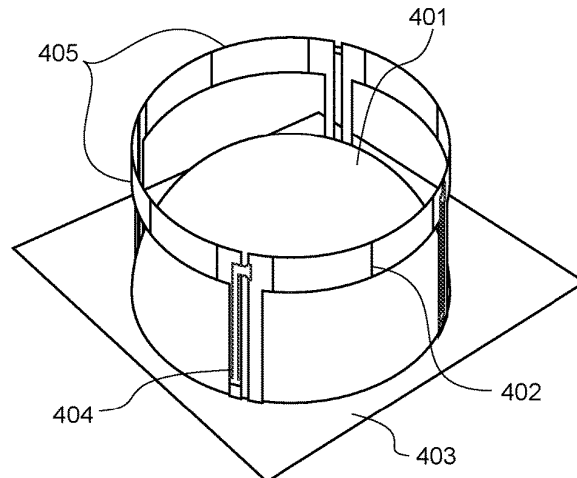
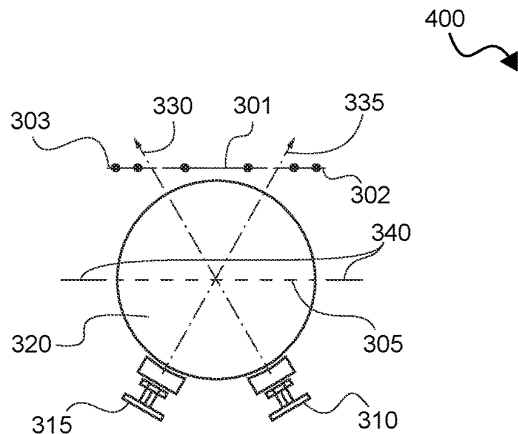



US012362467B2

(12) **United States Patent**  
**Chase et al.**

(10) **Patent No.:** **US 12,362,467 B2**  
(45) **Date of Patent:** **\*Jul. 15, 2025**

(54) **SMALL CELL INSTALLATION STRUCTURE**

(58) **Field of Classification Search**

(71) Applicant: **EasyStreet Systems, Inc.**, Spokane, WA (US)

CPC ..... H01Q 1/44; H01Q 1/368; H01Q 1/246; H01Q 1/1242  
See application file for complete search history.

(72) Inventors: **Peter Joseph Chase**, Spokane, WA (US); **Kent Alton Harrison**, Spokane, WA (US)

(56) **References Cited**

U.S. PATENT DOCUMENTS

(73) Assignee: **EasyStreet Systems, Inc.**, Spokane, WA (US)

8,806,825 B2 \* 8/2014 Egan ..... E04F 13/045 52/302.1  
9,790,688 B2 \* 10/2017 Mustapha ..... E04D 13/006  
10,056,017 B2 \* 8/2018 Butler, III ..... B25J 1/04  
11,114,751 B2 \* 9/2021 Chase ..... H01Q 1/1242  
(Continued)

(\* ) Notice: Subject to any disclaimer, the term of this patent is extended or adjusted under 35 U.S.C. 154(b) by 25 days.

This patent is subject to a terminal disclaimer.

OTHER PUBLICATIONS

“Notice of Allowance”, U.S. Appl. No. 16/750,804, Jun. 30, 2021, 8 pages.

(Continued)

(21) Appl. No.: **18/347,719**

(22) Filed: **Jul. 6, 2023**

*Primary Examiner* — Lam T Mai

(65) **Prior Publication Data**

US 2023/0352822 A1 Nov. 2, 2023

(74) *Attorney, Agent, or Firm* — FIG. 1 Patents

**Related U.S. Application Data**

(57) **ABSTRACT**

(63) Continuation of application No. 17/388,487, filed on Jul. 29, 2021, now Pat. No. 11,742,568, which is a continuation of application No. 16/750,804, filed on Jan. 23, 2020, now Pat. No. 11,114,751.

In aspects of a small cell installation structure, a support structure provides stability and an attachable framework to mount wireless technology equipment. A formable aesthetic housing is formed around the support structure, and a hardened polymer coating over the formable aesthetic housing is adapted to a shape of the formable aesthetic housing and the support structure. The hardened polymer coating resists environmental conditions that may otherwise interfere with performance of the wireless technology equipment. Additionally, an antenna housing module encloses antennas of the wireless technology equipment, is integrated with the support structure, and is designed to pass millimeter wave (mmW) spectrum wireless signals.

(60) Provisional application No. 62/900,336, filed on Sep. 13, 2019.

(51) **Int. Cl.**

**H01Q 1/36** (2006.01)  
**H01Q 1/24** (2006.01)  
**H01Q 1/44** (2006.01)

(52) **U.S. Cl.**

CPC ..... **H01Q 1/368** (2013.01); **H01Q 1/246** (2013.01); **H01Q 1/44** (2013.01)

**20 Claims, 8 Drawing Sheets**

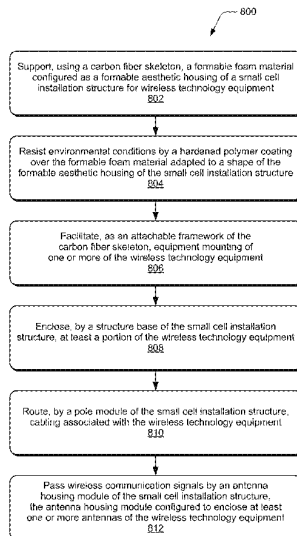



US012362469B2

(12) **United States Patent**  
**Chen**

(10) **Patent No.:** **US 12,362,469 B2**  
(45) **Date of Patent:** **Jul. 15, 2025**

(54) **ANTENNA DEVICE**  
(71) Applicant: **PanelSemi Corporation**, New Taipei (TW)  
(72) Inventor: **Hsien-Te Chen**, Taipei (TW)  
(73) Assignee: **PANELSEMI CORPORATION**, New Taipei (TW)  
(\* ) Notice: Subject to any disclaimer, the term of this patent is extended or adjusted under 35 U.S.C. 154(b) by 210 days.

(21) Appl. No.: **18/340,124**  
(22) Filed: **Jun. 23, 2023**  
(65) **Prior Publication Data**  
US 2023/0420832 A1 Dec. 28, 2023  
(30) **Foreign Application Priority Data**  
Jun. 24, 2022 (TW) ..... 111123737

(51) **Int. Cl.**  
**H01Q 1/38** (2006.01)  
(52) **U.S. Cl.**  
CPC ..... **H01Q 1/38** (2013.01)  
(58) **Field of Classification Search**  
CPC ..... H01Q 1/38; H01Q 9/0414; H01Q 9/0457; H01Q 21/065; H01Q 1/2283  
See application file for complete search history.

(56) **References Cited**  
U.S. PATENT DOCUMENTS  
2019/0319349 A1\* 10/2019 Loeher ..... H01Q 9/0407  
2020/0328167 A1\* 10/2020 Chang Chien ..... H01Q 1/38  
2024/0022004 A1\* 1/2024 Sakurai ..... H01Q 19/021  
\* cited by examiner  
*Primary Examiner* — Renan Luque  
(74) *Attorney, Agent, or Firm* — Muncy, Geissler, Olds & Lowe, P.C

(57) **ABSTRACT**  
An antenna device includes a first substrate, plural antenna elements, a second substrate, plural circuit units, plural circuit patterned layers and plural conductive structures. The first substrate is defined with a first surface and a second surface opposite to each other. The antenna elements are arranged on the first surface of the first substrate. The second substrate is connected to the second surface of the first substrate. The circuit units are arranged at the second substrate. The circuit patterned layers are arranged on the first substrate and the second substrate. The conductive structures are connected to at least ones of the circuit patterned layers. One of the circuit patterned layers includes plural induction units corresponding to the antenna elements, at least ones of the circuit units correspond to the induction units, and the induction units and the antenna elements transmit a carrier signal to each other by electro-magnetic induction.

**10 Claims, 5 Drawing Sheets**

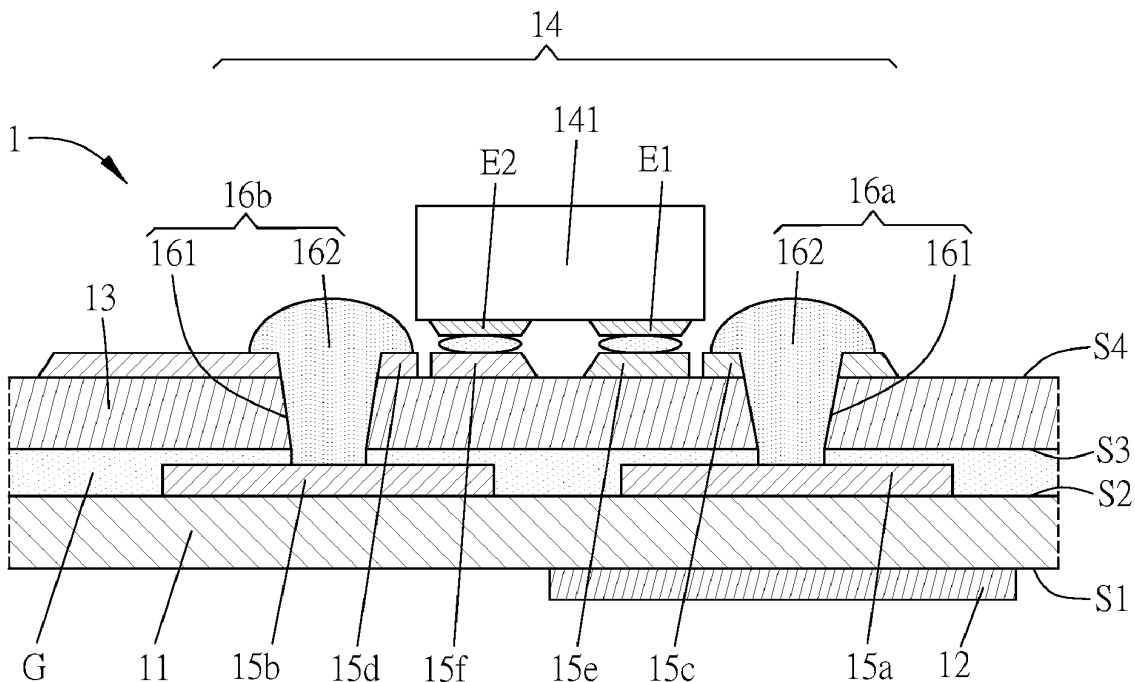



US012362477B2

(12) **United States Patent**  
**Franson**

(10) **Patent No.:** **US 12,362,477 B2**  
(45) **Date of Patent:** **Jul. 15, 2025**

(54) **INTEGRATED ANTENNA ARRAY AND BEAMFORMER IC CHIPS WITH INTER-STAGE AMPLIFICATION**

(58) **Field of Classification Search**  
CPC ..... H01Q 3/36; H01Q 1/2283; H01Q 1/48  
See application file for complete search history.

(71) Applicant: **VIASAT, INC.**, Carlsbad, CA (US)

(56) **References Cited**

(72) Inventor: **Steven J. Franson**, Scottsdale, AZ (US)

U.S. PATENT DOCUMENTS

(73) Assignee: **VIASAT, INC.**, Carlsbad, CA (US)

2013/0113657 A1 5/2013 Behbahani et al.  
2013/0308717 A1\* 11/2013 Maltsev ..... H04B 7/0417  
375/267

(\* ) Notice: Subject to any disclaimer, the term of this patent is extended or adjusted under 35 U.S.C. 154(b) by 303 days.

(Continued)

FOREIGN PATENT DOCUMENTS

(21) Appl. No.: **18/001,026**

CN 109155459 A 1/2019  
KR 10-2012-0091888 A 8/2012  
KR 10-2017-0070816 A 6/2017

(22) PCT Filed: **Mar. 4, 2021**

OTHER PUBLICATIONS

(86) PCT No.: **PCT/US2021/020973**

§ 371 (c)(1),  
(2) Date: **Dec. 7, 2022**

International Search Report and Written Opinion dated Jun. 2, 20219 in corresponding PCT Application No. PCT/US2021/020973 (10 pages).

(87) PCT Pub. No.: **WO2021/252036**

PCT Pub. Date: **Dec. 16, 2021**

*Primary Examiner* — Timothy A Brainard  
*Assistant Examiner* — Helena H Seraydaryan  
(74) *Attorney, Agent, or Firm* — F. CHAU & ASSOCIATES, LLC

(65) **Prior Publication Data**

US 2023/0223686 A1 Jul. 13, 2023

(57) **ABSTRACT**

**Related U.S. Application Data**

(60) Provisional application No. 63/038,091, filed on Jun. 11, 2020.

An antenna apparatus includes a first component layer having a plurality of antenna elements forming an antenna array. A second component layer includes: (i) a plurality of RFICs coupled to the antenna elements, where each RFIC has active beamforming circuitry to adjust signals communicated with one or more of the antenna elements, and a portion of a first stage of a beamforming network (BFN); and (ii) an additional stage and a further stage of the BFN, each disposed externally of the RFICs. At least some of the RFICs include an intermediate amplifier coupled between the additional and further stages of the BFN.

(51) **Int. Cl.**  
**H01Q 3/36** (2006.01)  
**H01Q 1/22** (2006.01)

(Continued)

**20 Claims, 8 Drawing Sheets**

(52) **U.S. Cl.**  
CPC ..... **H01Q 3/36** (2013.01); **H01Q 1/2283** (2013.01); **H01Q 1/48** (2013.01); **H01Q 9/0407** (2013.01)

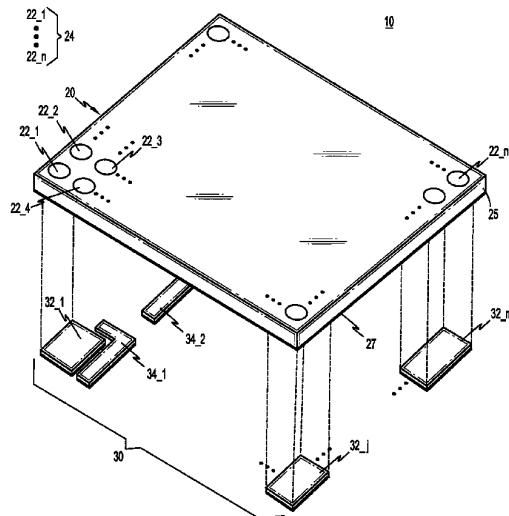



US012362481B2

(12) **United States Patent**  
**Li et al.**

(10) **Patent No.:** **US 12,362,481 B2**  
(45) **Date of Patent:** **Jul. 15, 2025**

(54) **TUNABLE ANTENNA, METHOD FOR PREPARING THE SAME, AND ELECTRONIC DEVICE USING THE SAME**

(52) **U.S. Cl.**  
CPC ..... **H01Q 5/364** (2015.01); **H01Q 1/243** (2013.01); **H01Q 9/14** (2013.01); **H01Q 9/42** (2013.01);

(71) Applicants: **BEIJING BOE TECHNOLOGY DEVELOPMENT CO., LTD.**, Beijing (CN); **BOE TECHNOLOGY GROUP CO., LTD.**, Beijing (CN)

(Continued)  
(58) **Field of Classification Search**  
CPC ..... H01Q 5/30; H01Q 5/357; H01Q 5/364; H01Q 5/40; H01Q 5/50; H01Q 9/14; (Continued)

(72) Inventors: **Chunxin Li**, Beijing (CN); **Jingwen Guo**, Beijing (CN); **Qianhong Wu**, Beijing (CN); **Zibo Cao**, Beijing (CN); **Feng Qu**, Beijing (CN)

(56) **References Cited**

U.S. PATENT DOCUMENTS

(73) Assignees: **BEIJING BOE TECHNOLOGY DEVELOPMENT CO., LTD.**, Beijing (CN); **BOE TECHNOLOGY GROUP CO., LTD.**, Beijing (CN)

4,751,513 A 6/1988 Daryoush et al.  
6,204,819 B1\* 3/2001 Hayes ..... H01Q 1/38 343/702

(Continued)

(\*) Notice: Subject to any disclaimer, the term of this patent is extended or adjusted under 35 U.S.C. 154(b) by 0 days.

FOREIGN PATENT DOCUMENTS

CN 106299630 A 1/2017  
CN 114188707 A 3/2022  
JP 2007-142721 A 6/2007

*Primary Examiner* — Jason M Crawford  
(74) *Attorney, Agent, or Firm* — WHDA, LLP

(21) Appl. No.: **18/021,423**

(22) PCT Filed: **Jun. 29, 2022**

(86) PCT No.: **PCT/CN2022/102481**  
§ 371 (c)(1),  
(2) Date: **Feb. 15, 2023**

(87) PCT Pub. No.: **WO2024/000306**  
PCT Pub. Date: **Jan. 4, 2024**

(65) **Prior Publication Data**  
US 2024/0266732 A1 Aug. 8, 2024

(51) **Int. Cl.**  
**H01Q 5/364** (2015.01)  
**H01Q 1/24** (2006.01)  
(Continued)

(57) **ABSTRACT**

The disclosure provides a tunable antenna, a method for preparing the tunable antenna and an electronic device, wherein the tunable antenna includes a substrate, and a microstrip feeder and a plurality of antennas arranged at intervals on a side of the substrate, wherein the microstrip feeder is configured to provide a coupling signal; and a control switch, arranged between the microstrip feeder and the plurality of antennas, and/or between at least two adjacent antennas the plurality of antennas, wherein the control switch is configured to control conduction between the microstrip feeder and at least one of the plurality of antennas, so as to output the coupling signal provided by the microstrip feeder into electromagnetic waves of different frequency bands.

**7 Claims, 13 Drawing Sheets**

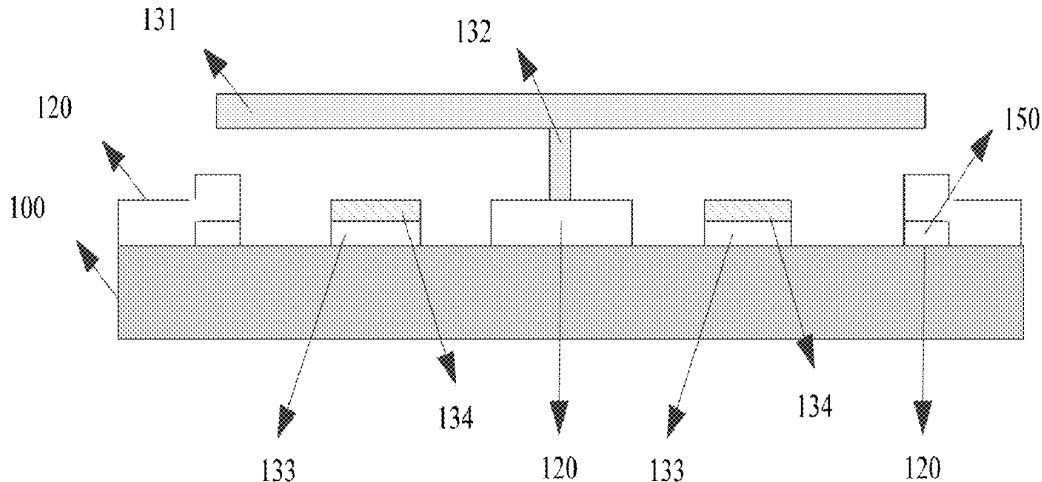



US012362483B2

(12) **United States Patent**  
**Yu et al.**

(10) **Patent No.:** **US 12,362,483 B2**  
(45) **Date of Patent:** **Jul. 15, 2025**

(54) **ANTENNA UNIT AND ELECTRONIC DEVICE**

(71) Applicant: **Huawei Technologies Co., Ltd.**,  
Shenzhen (CN)

(72) Inventors: **Dong Yu**, Shanghai (CN); **Kexin Liu**,  
Shanghai (CN); **Yuan Zhou**, Shanghai  
(CN); **Hanyang Wang**, Reading (GB);  
**Lijun Ying**, Shanghai (CN); **Pengfei**  
**Wu**, Shanghai (CN); **Chien-Ming Lee**,  
Shenzhen (CN); **Meng Hou**, Shanghai  
(CN)

(73) Assignee: **HUAWEI TECHNOLOGIES CO.,  
LTD.**, Shenzhen (CN)

(\*) Notice: Subject to any disclaimer, the term of this  
patent is extended or adjusted under 35  
U.S.C. 154(b) by 354 days.

(21) Appl. No.: **17/920,570**

(22) PCT Filed: **Mar. 25, 2021**

(86) PCT No.: **PCT/CN2021/082974**

§ 371 (c)(1),

(2) Date: **Oct. 21, 2022**

(87) PCT Pub. No.: **WO2021/213125**

PCT Pub. Date: **Oct. 28, 2021**

(65) **Prior Publication Data**

US 2023/0163466 A1 May 25, 2023

(30) **Foreign Application Priority Data**

Apr. 22, 2020 (CN) ..... 202010323918.5

(51) **Int. Cl.**

**H01Q 7/00** (2006.01)

**H01Q 1/52** (2006.01)

**H01Q 5/35** (2015.01)

(52) **U.S. Cl.**

CPC ..... **H01Q 7/00** (2013.01); **H01Q 1/521**  
(2013.01); **H01Q 5/35** (2015.01)

(58) **Field of Classification Search**

CPC ..... H01Q 1/521; H01Q 5/35; H01Q 7/00  
See application file for complete search history.

(56) **References Cited**

U.S. PATENT DOCUMENTS

4,395,714 A \* 7/1983 Takeda ..... H01Q 9/30  
343/701  
2009/0160717 A1\* 6/2009 Tsutsumi ..... H01Q 19/30  
343/726

(Continued)

FOREIGN PATENT DOCUMENTS

CN 102299406 A 12/2011  
CN 107425258 A 12/2017

(Continued)

OTHER PUBLICATIONS

Mahadik Shamala Rajaram, Compact multiband antenna with folded  
meandered loop: LTE/WLAN/WiMAX advanced mobile opera-  
tions, <https://ieeexplore.ieee.org/document/8300028>, Mar. 22-24,  
2017, total 5 pages.

*Primary Examiner* — Dameon E Levi

*Assistant Examiner* — Leah Rosenberg

(74) *Attorney, Agent, or Firm* — Slater Matsil, LLP

(57) **ABSTRACT**

This application provides an antenna unit and an electronic  
device. A signal at a C-mode port and a signal at a D-mode  
port of a same loop antenna in any antenna unit are respec-  
tively excited by using two feeds, and the antenna unit is  
electrically symmetrically disposed, so that the signal at the  
C-mode port is self-cancelled at the D-mode port, and the  
signal at the D-mode port is self-cancelled at the C-mode  
port, to implement signal isolation between the two ports  
and interference self-cancel, and the signal at the C-mode  
port and the signal at the D-mode port can be complemen-

(Continued)

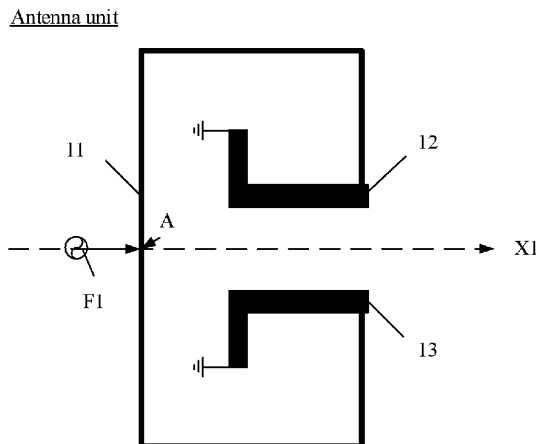



US012362484B2

(12) **United States Patent**  
**Chang et al.**

(10) **Patent No.:** **US 12,362,484 B2**  
(45) **Date of Patent:** **Jul. 15, 2025**

(54) **WIRELESS TRANSMISSION SYSTEM**

(56) **References Cited**

(71) Applicant: **BENQ CORPORATION**, Taipei (TW)

U.S. PATENT DOCUMENTS

(72) Inventors: **Chun-Yi Chang**, Taipei (TW);  
**Chih-Ming Chen**, Taipei (TW)

2012/0127039 A1\* 5/2012 Tsai ..... H01Q 1/22  
343/702  
2019/0281146 A1\* 9/2019 Jang ..... H01Q 21/06  
2020/0312798 A1\* 10/2020 Kawahata ..... G01S 7/03  
2021/0359423 A1 11/2021 Huang et al.

(73) Assignee: **BenQ Corporation**, Taipei (TW)

FOREIGN PATENT DOCUMENTS

(\*) Notice: Subject to any disclaimer, the term of this patent is extended or adjusted under 35 U.S.C. 154(b) by 184 days.

CN 104681993 A 6/2015  
TW 513828 B 12/2002

OTHER PUBLICATIONS

(21) Appl. No.: **18/110,399**

Office action of counterpart application by Taiwan IP Office on Sep. 16, 2022.

(22) Filed: **Feb. 16, 2023**

\* cited by examiner

(65) **Prior Publication Data**  
US 2023/0335906 A1 Oct. 19, 2023

*Primary Examiner* — David E Lotter

(30) **Foreign Application Priority Data**  
Apr. 18, 2022 (TW) ..... 111114688

(57) **ABSTRACT**

(51) **Int. Cl.**  
**H01Q 9/04** (2006.01)  
**H01Q 1/22** (2006.01)  
**H01Q 1/48** (2006.01)

A wireless transmission system includes a signal-transmitting device and a signal-receiving device. The signal-transmitting device is disposed in a remote-control apparatus for transmitting wireless signals wherein the remote-control apparatus is a mouse. The signal-receiving device is installed on an electronic apparatus to receive the wireless signals and trigger operations in response the wireless signals. The signal-receiving device includes a patch antenna including a dielectric substrate having a first surface and a second surface opposite to the first surface, a ground layer disposed on the first surface, and a radiating metal layer. The radiating metal layer is disposed on the second surface and includes a radiation receiving surface. A first position of the radiation receiving surface is separated from the ground layer by a first distance, and a second position of the radiation receiving surface is separated from the ground layer by a second distance less than the first distance.

(52) **U.S. Cl.**  
CPC ..... **H01Q 9/0407** (2013.01); **H01Q 1/2266** (2013.01); **H01Q 1/48** (2013.01)

(58) **Field of Classification Search**  
CPC ..... H01Q 9/0407; H01Q 1/2266; H01Q 1/48; H01Q 1/2258; H01Q 9/40; H01Q 9/0471  
See application file for complete search history.

**13 Claims, 10 Drawing Sheets**

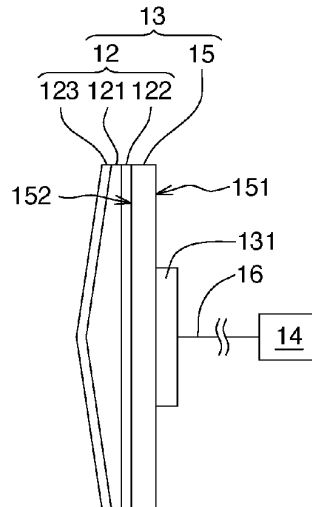
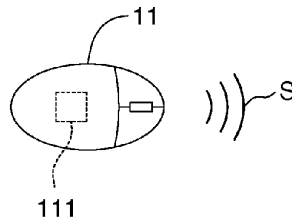



US012362486B2

(12) **United States Patent**  
**Chang et al.**

(10) **Patent No.:** **US 12,362,486 B2**  
(45) **Date of Patent:** **Jul. 15, 2025**

(54) **ANTENNA STRUCTURE**  
(71) Applicant: **Wistron NeWeb Corp.**, Hsinchu (TW)  
(72) Inventors: **Wei-Chung Chang**, Hsinchu (TW);  
**Shang-Ching Tseng**, Hsinchu (TW)  
(73) Assignee: **WISTRON NEWEB CORP.**, Hsinchu (TW)  
(\* ) Notice: Subject to any disclaimer, the term of this patent is extended or adjusted under 35 U.S.C. 154(b) by 174 days.

(21) Appl. No.: **18/489,072**  
(22) Filed: **Oct. 18, 2023**

(65) **Prior Publication Data**  
US 2024/0162618 A1 May 16, 2024

(30) **Foreign Application Priority Data**  
Nov. 15, 2022 (TW) ..... 111143468

(51) **Int. Cl.**  
**H01Q 1/24** (2006.01)  
**H01Q 1/38** (2006.01)  
**H01Q 5/20** (2015.01)  
**H01Q 5/314** (2015.01)  
**H01Q 9/04** (2006.01)  
**H01Q 23/00** (2006.01)  
(52) **U.S. Cl.**  
CPC ..... **H01Q 9/0442** (2013.01); **H01Q 5/20** (2015.01); **H01Q 5/314** (2015.01); **H01Q 23/00** (2013.01)

(58) **Field of Classification Search**  
CPC .. H01Q 1/24; H01Q 1/38; H01Q 1/48; H01Q 23/00; H01Q 5/20; H01Q 5/31; H01Q 5/314; H01Q 5/32; H01Q 5/328; H01Q 5/37; H01Q 5/378; H01Q 9/04; H01Q 9/0442

See application file for complete search history.

(56) **References Cited**  
U.S. PATENT DOCUMENTS  
9,923,263 B2 \* 3/2018 Yen ..... H01Q 9/0421  
10,522,902 B1 \* 12/2019 Tseng ..... H01Q 1/48  
11,075,460 B2 \* 7/2021 Yu ..... H01Q 13/16  
11,128,050 B1 \* 9/2021 Chuang ..... H01Q 5/371  
11,139,559 B2 \* 10/2021 Wei ..... H01Q 5/364  
11,264,699 B2 \* 3/2022 Chang ..... H01Q 1/2291  
11,588,245 B2 2/2023 Wei

FOREIGN PATENT DOCUMENTS  
TW 201902032 A 1/2019  
TW 202021188 A 6/2020

\* cited by examiner  
*Primary Examiner* — Tho G Phan  
(74) *Attorney, Agent, or Firm* — McClure, Qualey & Rodack, LLP

(57) **ABSTRACT**  
An antenna structure includes a metal mechanism element, a ground element, a feeding radiation element, a first radiation element, a second radiation element, a parasitic radiation element, a tuning circuit, and a nonconductive support element. The metal mechanism element has a slot. The metal mechanism element includes a first grounding portion and a second grounding portion. The slot is positioned between the first grounding portion and the second grounding portion. The feeding radiation element has a feeding point. The first radiation element is coupled to the feeding radiation element. The second radiation element is coupled to the feeding radiation element. The parasitic radiation element is coupled to the ground element. The parasitic radiation element is adjacent to the first radiation element and the second radiation element. The tuning circuit is coupled between the first grounding portion and the second grounding portion of the metal mechanism element.

**20 Claims, 6 Drawing Sheets**

100

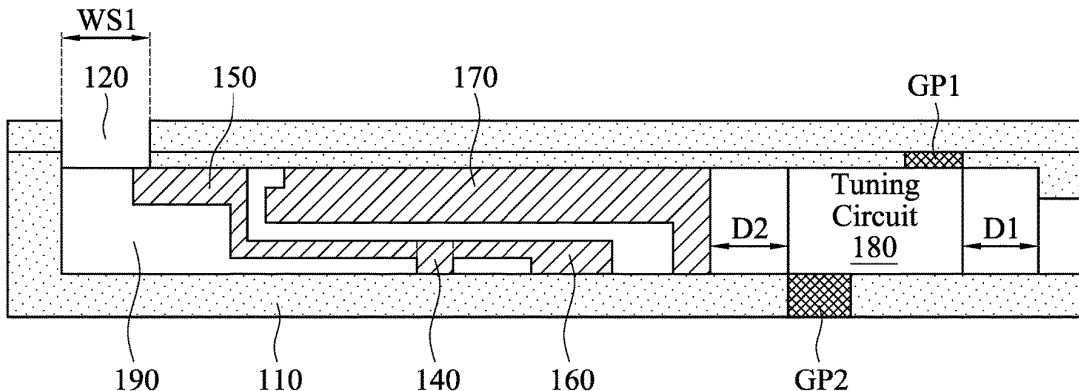



US012362488B2

(12) **United States Patent**  
**Garrido Lopez et al.**

(10) **Patent No.:** **US 12,362,488 B2**  
(45) **Date of Patent:** **Jul. 15, 2025**

(54) **ELECTRONIC DEVICES WITH DIELECTRIC RESONATOR ANTENNAS**

(71) Applicant: **Apple Inc.**, Cupertino, CA (US)  
(72) Inventors: **David Garrido Lopez**, San Jose, CA (US); **Panagiotis Theofanopoulos**, Cupertino, CA (US); **Harish Rajagopalan**, San Jose, CA (US); **Subramanian Ramalingam**, San Jose, CA (US); **Forhad Hasnat**, Milpitas, CA (US); **Rodney A Gomez Angulo**, Santa Clara, CA (US); **Robert Scritzky**, Sunnyvale, CA (US)

(73) Assignee: **Apple Inc.**, Cupertino, CA (US)  
(\* ) Notice: Subject to any disclaimer, the term of this patent is extended or adjusted under 35 U.S.C. 154(b) by 99 days.

(21) Appl. No.: **18/167,567**

(22) Filed: **Feb. 10, 2023**

(65) **Prior Publication Data**

US 2024/0113436 A1 Apr. 4, 2024

**Related U.S. Application Data**

(60) Provisional application No. 63/412,768, filed on Oct. 3, 2022.

(51) **Int. Cl.**  
**H01Q 9/04** (2006.01)  
**H01Q 1/24** (2006.01)  
**H01Q 3/30** (2006.01)

(52) **U.S. Cl.**  
CPC ..... **H01Q 9/0485** (2013.01); **H01Q 1/241** (2013.01); **H01Q 1/243** (2013.01); **H01Q 3/30** (2013.01)

(58) **Field of Classification Search**  
CPC ..... H01Q 1/241; H01Q 1/243; H01Q 3/30; H01Q 9/0485  
See application file for complete search history.

(56) **References Cited**

U.S. PATENT DOCUMENTS

6,496,147 B1 12/2002 Kirino  
10,312,601 B2 6/2019 Zhai et al.  
(Continued)

FOREIGN PATENT DOCUMENTS

CN 112928478 A \* 6/2021 ..... H01Q 25/04  
CN 113506989 A 10/2021  
(Continued)

OTHER PUBLICATIONS

S. Sibó, "Design of Step-Shaped Dielectric Resonator Antenna Element," 2022 IEEE 10th Asia-Pacific Conference on Antennas and Propagation (APCAP), Xiamen, China, 2022, pp. 1-2, doi: 10.1109/APCAP56600.2022.10068963. (Year: 2022).\*

*Primary Examiner* — Dameon E Levi

*Assistant Examiner* — Leah Rosenberg

(74) *Attorney, Agent, or Firm* — Treyz Law Group, P.C.; Tianyi He

(57) **ABSTRACT**

An electronic device may be provided with a phased antenna array that radiates at a frequency greater than 10 GHz. The array may include a first set of dielectric resonator antennas arranged in a first row and a second set of dielectric resonator antennas in a second row offset from the first row. Each dielectric resonator antenna may have dielectric resonating element with a base portion and a stepped portion. The stepped portions of the antennas in the first set may be arranged to be distant from the stepped portions of the antennas in the second set. The antennas in the first set may be arranged to be more distant from an electronic device sidewall than the antennas in the second set. Configured in this manner, the array may exhibit reduced inter-coupling between dielectric resonator antennas in the first set and dielectric resonator antennas in the second set.

**20 Claims, 13 Drawing Sheets**

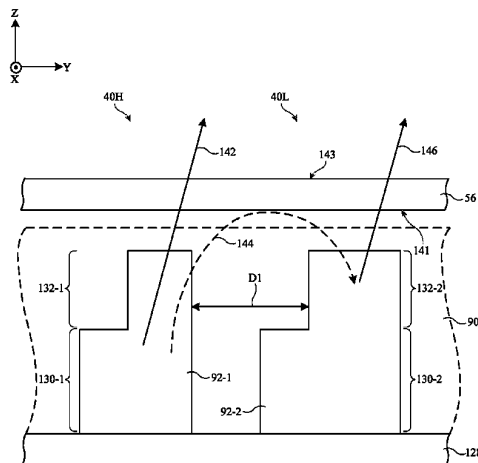



US012362492B2

(12) **United States Patent**  
**Lin et al.**

(10) **Patent No.:** **US 12,362,492 B2**  
(45) **Date of Patent:** **Jul. 15, 2025**

(54) **MULTI-BAND ANTENNA AND ELECTRONIC DEVICE**

(71) Applicant: **Wistron NeWeb Corporation**, Hsinchu (TW)

(72) Inventors: **Hung-Ying Lin**, Hsinchu (TW); **Wen Tai Tseng**, Hsinchu (TW); **Kuo Jen Lai**, Hsinchu (TW)

(73) Assignee: **WISTRON NEWEB CORPORATION**, Hsinchu (TW)

(\* ) Notice: Subject to any disclaimer, the term of this patent is extended or adjusted under 35 U.S.C. 154(b) by 146 days.

(21) Appl. No.: **18/500,268**

(22) Filed: **Nov. 2, 2023**

(65) **Prior Publication Data**  
US 2024/0154309 A1 May 9, 2024

(30) **Foreign Application Priority Data**  
Nov. 4, 2022 (TW) ..... 111142265

(51) **Int. Cl.**  
**H01Q 9/42** (2006.01)  
**H01Q 5/378** (2015.01)  
**H01Q 1/22** (2006.01)

(52) **U.S. Cl.**  
CPC ..... **H01Q 9/42** (2013.01); **H01Q 5/378** (2015.01); **H01Q 1/2291** (2013.01)

(58) **Field of Classification Search**  
CPC ..... H01Q 1/2291; H01Q 1/243; H01Q 5/30; H01Q 5/378

See application file for complete search history.

(56) **References Cited**

U.S. PATENT DOCUMENTS

8,779,989 B2\* 7/2014 Huang ..... H01Q 9/42 343/848  
2019/0044232 A1\* 2/2019 Tseng ..... H01Q 1/245

\* cited by examiner

*Primary Examiner* — Daniel Munoz

(74) *Attorney, Agent, or Firm* — McClure, Qualey & Rodack, LLP

(57) **ABSTRACT**

A multi-band antenna includes a substrate with a first surface and a second surface, a first antenna structure with a first antenna coupling segment, a second antenna structure with a second antenna coupling segment, a first grounding section, a coupling section, a via hole, and a second grounding section. Both of the first antenna structure and the second antenna structure are disposed on the first surface. The first grounding section is connected to the first antenna coupling segment. The coupling section is disposed on the second surface and projected onto the first surface to form a coupling region. Both of the first antenna coupling segment and the second antenna coupling segment at least partially overlap the coupling region. The via hole penetrates through the substrate and is connected between the coupling section and the second antenna coupling segment. The second grounding section is connected to the coupling section.

**20 Claims, 7 Drawing Sheets**

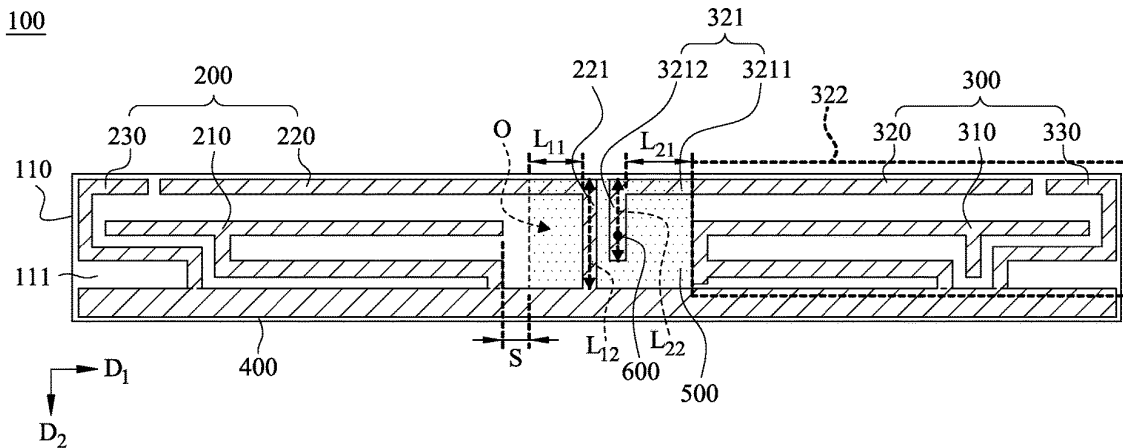



US012362495B2

(12) **United States Patent**  
**Zhang et al.**

(10) **Patent No.:** **US 12,362,495 B2**  
(45) **Date of Patent:** **Jul. 15, 2025**

(54) **ANTENNA, ANTENNA ARRAY AND ELECTRONIC DEVICE**

(71) Applicant: **BOE TECHNOLOGY GROUP CO., LTD.**, Beijing (CN)

(72) Inventors: **Shiqiao Zhang**, Beijing (CN); **Jia Fang**, Beijing (CN); **Feng Qu**, Beijing (CN); **Yang Zheng**, Beijing (CN); **Cheng Pan**, Beijing (CN)

(73) Assignee: **BOE TECHNOLOGY GROUP CO., LTD.**, Beijing (CN)

(\*) Notice: Subject to any disclaimer, the term of this patent is extended or adjusted under 35 U.S.C. 154(b) by 0 days.

(21) Appl. No.: **18/024,753**

(22) PCT Filed: **Jun. 13, 2022**

(86) PCT No.: **PCT/CN2022/098377**

§ 371 (c)(1),  
(2) Date: **Mar. 4, 2023**

(87) PCT Pub. No.: **WO2023/240396**

PCT Pub. Date: **Dec. 21, 2023**

(65) **Prior Publication Data**

US 2024/0283161 A1 Aug. 22, 2024

(51) **Int. Cl.**  
**H01Q 15/00** (2006.01)  
**H01Q 1/38** (2006.01)

(52) **U.S. Cl.**  
CPC ..... **H01Q 15/0066** (2013.01); **H01Q 1/38** (2013.01)

(58) **Field of Classification Search**

CPC ..... H01Q 15/0066; H01Q 1/38; H01Q 1/36; G02F 1/13; G02F 1/1343; H01P 1/18  
See application file for complete search history.

(56) **References Cited**

U.S. PATENT DOCUMENTS

11,196,134 B2 \* 12/2021 Kong ..... H01P 1/184  
11,837,802 B2 \* 12/2023 Wu ..... H01Q 1/38  
2021/0376434 A1 12/2021 Li et al.  
2022/0140800 A1 5/2022 Fang et al.

FOREIGN PATENT DOCUMENTS

CN 104409860 A 3/2015  
CN 107706513 A 2/2018  
CN 108718001 A 10/2018

(Continued)

*Primary Examiner* — Seung H Lee

(74) *Attorney, Agent, or Firm* — HOUTTEMAN LAW LLC

(57) **ABSTRACT**

An antenna, an antenna array and an electronic device are provided and belong to the field of communication technology. The antenna includes a first substrate, a second substrate, and a tunable dielectric layer. The first substrate includes a first dielectric substrate and a first electrode layer on a side of the first dielectric substrate close to the tunable dielectric layer; the second substrate includes a second dielectric substrate and a second electrode layer on a side of the second dielectric substrate close to the tunable dielectric layer. The second electrode layer includes a signal electrode, and at least one first branch and at least one second branch electrically connected to the signal electrode; the at least one first branch and the at least one second branch are respectively on two sides of an extending direction of the signal electrode.

**17 Claims, 7 Drawing Sheets**

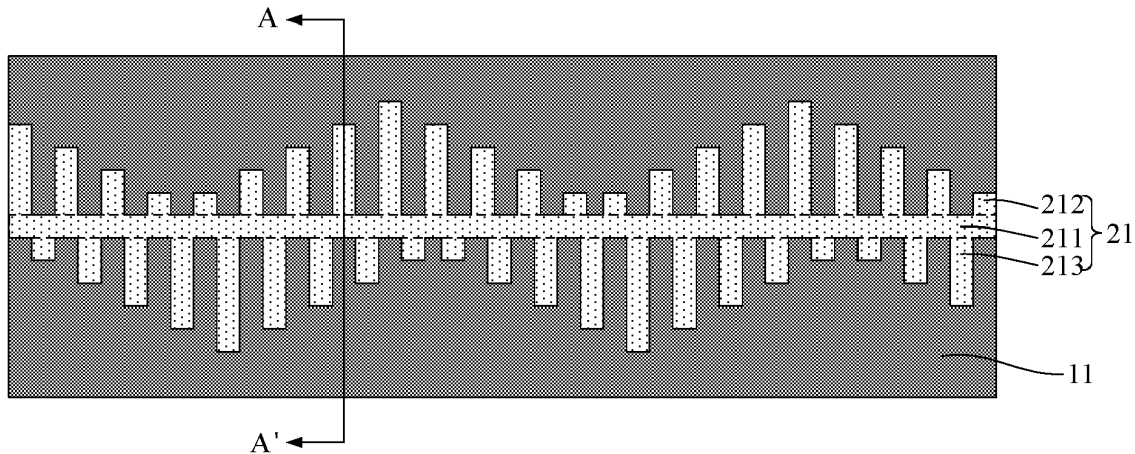



US012362499B1

(12) **United States Patent**  
**Sikina et al.**

(10) **Patent No.:** **US 12,362,499 B1**  
(45) **Date of Patent:** **Jul. 15, 2025**

(54) **POLARIZATION VERSATILE RADIATOR**

6,005,531 A \* 12/1999 Cassen ..... H01Q 21/0025  
343/754

(71) Applicant: **Raytheon Company**, Waltham, MA (US)

6,507,320 B2 1/2003 Von Stein et al.  
6,608,535 B2 8/2003 Sherman et al.  
6,624,787 B2 9/2003 Puzella et al.  
7,671,696 B1 3/2010 Puzella et al.  
8,279,131 B2 10/2012 Puzella et al.

(72) Inventors: **Thomas V. Sikina**, Acton, MA (US);  
**Jack J. Schuss**, Newton, MA (US);  
**Izabella Furman**, Natick, MA (US);  
**Robert S. Isom**, Allen, TX (US)

(Continued)

FOREIGN PATENT DOCUMENTS

(73) Assignee: **Raytheon Company**, Waltham, MA (US)

JP 11068448 A 3/1999  
JP 2000261235 9/2000  
JP 2006279474 10/2006

(\* ) Notice: Subject to any disclaimer, the term of this patent is extended or adjusted under 35 U.S.C. 154(b) by 2670 days.

OTHER PUBLICATIONS

(21) Appl. No.: **14/999,923**

Communication Pursuant to Rules 161(1) and 162 EPC for European Application No. 17826059.2 dated Jul. 23, 2019; 3 Pages.

(22) Filed: **Dec. 16, 2016**

(Continued)

(51) **Int. Cl.**

**H01Q 21/00** (2006.01)  
**H01Q 9/04** (2006.01)  
**H01Q 21/06** (2006.01)  
**H01Q 21/24** (2006.01)

Primary Examiner — Peter M Bythrow

(74) *Attorney, Agent, or Firm* — DALY, CROWLEY, MOFFORD & DURKEE LLP

(52) **U.S. Cl.**

CPC ..... **H01Q 21/00** (2013.01); **H01Q 9/04** (2013.01); **H01Q 21/06** (2013.01); **H01Q 21/24** (2013.01)

(57) **ABSTRACT**

(58) **Field of Classification Search**

CPC ..... H01Q 21/00; H01Q 21/0006; H01Q 21/0031; H01Q 21/0043; H01Q 21/005; H01Q 21/06; H01Q 21/031; H01Q 21/064; H01Q 21/24; H01Q 21/245; H01Q 9/04

A unit cell of an array antenna includes an integrated dilation and feed circuit and an associated radiator assembly. The integrated dilation and feed circuit includes an asymmetric dilation layer, an asymmetric combiner layer, a symmetric feed layer and a symmetric slot layer. Feed circuits on the feed layer are configured to couple radio frequency (RF) signals to/from a pair of orthogonally disposed slot elements symmetrically disposed on the slot layer of the integrated dilation-feed circuit. The slot layer couples signals to and from the radiator assembly. Such unit cell may be used to provide an array antenna including an active electronically scanned array (AESA) antenna.

See application file for complete search history.

(56) **References Cited**

U.S. PATENT DOCUMENTS

5,268,701 A \* 12/1993 Smith ..... H01Q 21/24  
343/770  
5,786,792 A \* 7/1998 Bellus ..... H01Q 21/0087  
343/770

**24 Claims, 7 Drawing Sheets**

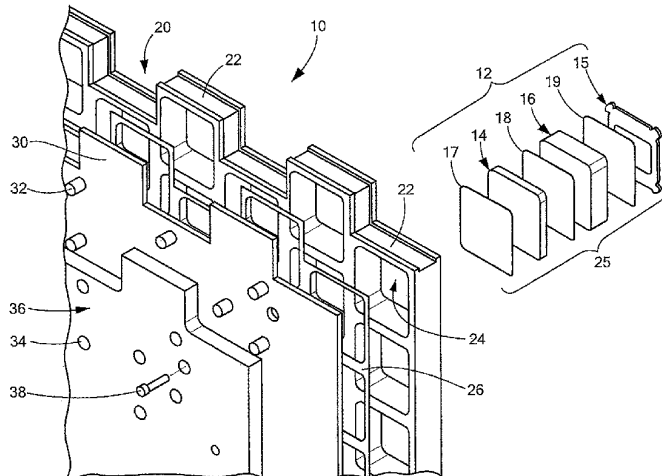



US012362772B2

(12) **United States Patent**  
**Epstein**

(10) **Patent No.:** **US 12,362,772 B2**  
(45) **Date of Patent:** **Jul. 15, 2025**

(54) **FLEXIBLE WIRELESS INTERCONNECTION AND BOARD DIVERSITY**

(56) **References Cited**

(71) Applicant: **OMNIFI INC.**, Pleasanton, CA (US)

U.S. PATENT DOCUMENTS

(72) Inventor: **Joseph Alan Epstein**, Pleasanton, CA (US)

7,231,224 B1 6/2007 Chesson  
8,705,967 B2 4/2014 Beach  
12,035,186 B2 \* 7/2024 Salas Moreno ..... H04B 10/116  
(Continued)

(73) Assignee: **Omnifi Inc.**, Pleasanton, CA (US)

FOREIGN PATENT DOCUMENTS

(\* ) Notice: Subject to any disclaimer, the term of this patent is extended or adjusted under 35 U.S.C. 154(b) by 663 days.

KR 101635182 B1 6/2016

OTHER PUBLICATIONS

(21) Appl. No.: **17/379,197**

International Search Report and Written Opinion for Application No. PCT/US2021/42158, mailed on Oct. 22, 2021, 48 pages.

(22) Filed: **Jul. 19, 2021**

(Continued)

(65) **Prior Publication Data**

US 2022/0029649 A1 Jan. 27, 2022

*Primary Examiner* — Pablo N Tran

(74) *Attorney, Agent, or Firm* — Baker Botts L.L.P.

(57) **ABSTRACT**

**Related U.S. Application Data**

(60) Provisional application No. 63/054,332, filed on Jul. 21, 2020.

Systems and methods for providing access to a wireless network include apparatus and manufacturing and configuration techniques. Embodiments include a head-end configured to receive electrical power and communicate with the wireless network. In an embodiment, a plurality of integrated access points each comprise components such as a radio, a power supply, a controller, a network transceiver, and an antenna. The components of each integrated access point, whether or not they are assembled on one or more rigid or flexible cards, may be embedded in a material expanse such as a flexible strip, upon which each set of components may be proximally integrated. In an embodiment, a system includes a unified backplane interconnect coupled to the head-end, the unified backplane interconnect comprising a plurality of interconnects. Each integrated access point may comprise a single radio, or more than one radio.

(51) **Int. Cl.**  
**H04B 1/03** (2006.01)  
**H01Q 1/24** (2006.01)  
**H01Q 23/00** (2006.01)  
**H04B 1/04** (2006.01)  
**H04B 1/16** (2006.01)

(52) **U.S. Cl.**  
CPC ..... **H04B 1/03** (2013.01); **H01Q 1/246** (2013.01); **H01Q 23/00** (2013.01); **H04B 1/04** (2013.01); **H04B 1/1607** (2013.01)

(58) **Field of Classification Search**  
None  
See application file for complete search history.

**12 Claims, 30 Drawing Sheets**

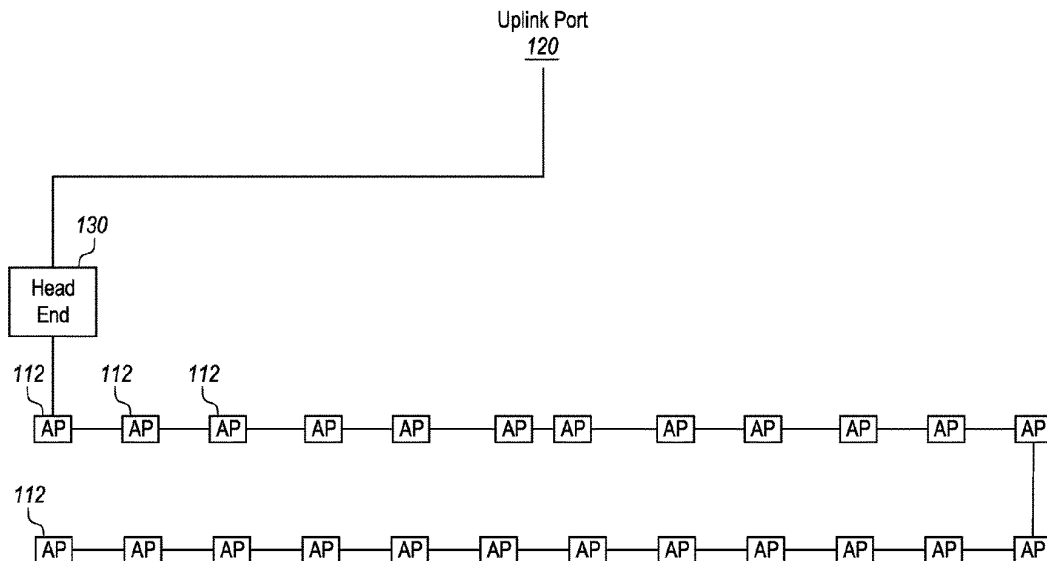



US012362809B2

(12) **United States Patent**  
**Raghavan et al.**

(10) **Patent No.:** **US 12,362,809 B2**  
(45) **Date of Patent:** **Jul. 15, 2025**

(54) **USER EQUIPMENT (UE) ANTENNA  
MODULE LOCK FUNCTION**

(71) Applicant: **QUALCOMM Incorporated**, San Diego, CA (US)

(72) Inventors: **Vasanthan Raghavan**, West Windsor Township, NJ (US); **Benjamin Cheadle**, San Diego, CA (US); **Raghu Narayan Challa**, San Diego, CA (US); **Mohammad Ali Tassoudji**, San Diego, CA (US)

(73) Assignee: **QUALCOMM Incorporated**, San Diego, CA (US)

(\* ) Notice: Subject to any disclaimer, the term of this patent is extended or adjusted under 35 U.S.C. 154(b) by 38 days.

(21) Appl. No.: **18/541,721**

(22) Filed: **Dec. 15, 2023**

(65) **Prior Publication Data**

US 2025/0202562 A1 Jun. 19, 2025

(51) **Int. Cl.**  
**H04L 5/12** (2006.01)  
**H04B 7/06** (2006.01)

(52) **U.S. Cl.**  
CPC ..... **H04B 7/0695** (2013.01); **H04B 7/0639** (2013.01)

(58) **Field of Classification Search**  
CPC ..... H04B 7/0695; H04B 7/0639  
USPC ..... 375/262, 260, 259, 219, 295, 316  
See application file for complete search history.

(56) **References Cited**

U.S. PATENT DOCUMENTS

2022/0225118 A1\* 7/2022 Pefkianakis ..... H04W 64/006  
\* cited by examiner

*Primary Examiner* — Zewdu A Kassa

(74) *Attorney, Agent, or Firm* — Holland & Hart LLP

(57) **ABSTRACT**

Methods, systems, and devices for wireless communications systems are described. A user equipment (UE) may receive, from a network entity, a set of beam-swept synchronization signals associated with a testing procedure for the UE. The UE may select a first beam pair associated with a first antenna module of the UE from a set of multiple beam pairs associated with the received synchronization signals. The UE may receive a first module lock command and a first beam lock command, and may utilize the commands in performing a first set of measurements of the first beam pair at the first antenna module. The UE may receive a first beam lock deactivation command to release the first beam lock command of the first beam pair, and a first module lock deactivation command to release the first module lock command of the first antenna module.

**30 Claims, 14 Drawing Sheets**

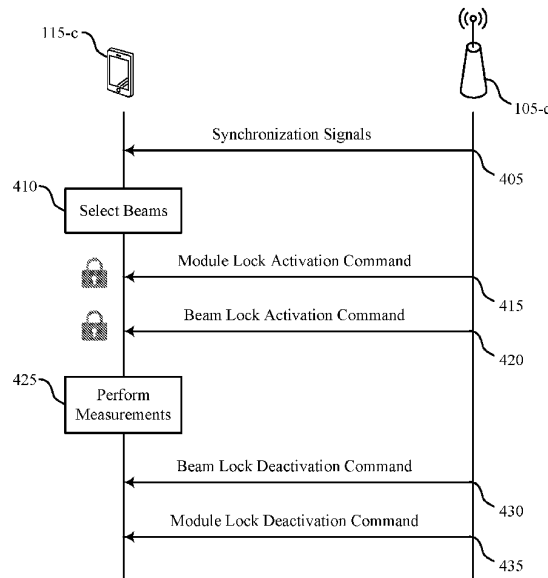

400



US012363211B2

(12) **United States Patent**  
**Hwang et al.**

(10) **Patent No.:** **US 12,363,211 B2**  
(45) **Date of Patent:** **Jul. 15, 2025**

(54) **ELECTRONIC DEVICE INCLUDING ANTENNAS**

(71) Applicant: **Samsung Electronics Co., Ltd.**,  
Gyeonggi-do (KR)

(72) Inventors: **Soonho Hwang**, Gyeonggi-do (KR);  
**Sungkoo Park**, Gyeonggi-do (KR);  
**Kyungjae Lee**, Gyeonggi-do (KR);  
**Sewoong Kim**, Gyeonggi-do (KR);  
**Seunghwan Kim**, Gyeonggi-do (KR);  
**Taek Kim**, Gyeonggi-do (KR)

(73) Assignee: **Samsung Electronics Co., Ltd.**,  
Suwon-si (KR)

(\* ) Notice: Subject to any disclaimer, the term of this patent is extended or adjusted under 35 U.S.C. 154(b) by 337 days.

(21) Appl. No.: **17/890,483**

(22) Filed: **Aug. 18, 2022**

(65) **Prior Publication Data**

US 2023/0046166 A1 Feb. 16, 2023

**Related U.S. Application Data**

(63) Continuation of application No. PCT/KR2022/011755, filed on Aug. 8, 2022.

(30) **Foreign Application Priority Data**

Aug. 9, 2021 (KR) ..... 10-2021-0104349

(51) **Int. Cl.**  
**H04M 1/02** (2006.01)

(52) **U.S. Cl.**  
CPC ..... **H04M 1/0245** (2013.01); **H04M 1/0216** (2013.01)

(58) **Field of Classification Search**  
CPC . H04L 41/0894; H04L 41/0895; H04L 41/40;  
H04W 4/50; H04W 48/08;

(Continued)

(56) **References Cited**

U.S. PATENT DOCUMENTS

10,305,166 B2 5/2019 Kim et al.  
10,418,689 B2 9/2019 Kim et al.  
(Continued)

FOREIGN PATENT DOCUMENTS

KR 10-2017-0019838 A 2/2017  
KR 10-2018-0137993 A 12/2018  
(Continued)

OTHER PUBLICATIONS

International Search Report dated Nov. 17, 2022.

*Primary Examiner* — Nathan S Taylor

(74) *Attorney, Agent, or Firm* — Cha & Reiter, LLC

(57) **ABSTRACT**

According to an embodiment, an electronic device comprises: a foldable housing comprising a first housing hingably connected to a second housing, a first side member disposed about a side surface of the first housing and comprising a first plurality of conductive parts, and a second side member disposed about a side surface of the second housing and comprising a second plurality of conductive parts; a communication circuit electrically connected to a first conductive part among the first plurality of conductive parts and configured to transmit and receive a signal in a selected or specified frequency band; a first sensor integrated circuit (IC) electrically connected to at least one of the first plurality of conductive parts and configured to measure capacitance; a second sensor IC electrically connected to at least one of the second plurality of conductive parts and configured to measure capacitance; a first switching circuit electrically connected to the first conductive part and a second conductive part among the first plurality of conductive parts; and a processor and a memory, wherein the memory stores instructions that, when executed, cause the processor to perform a plurality of operations, the plurality of operations comprising: controlling the first switching circuit wherein the first conductive part and the second

(Continued)

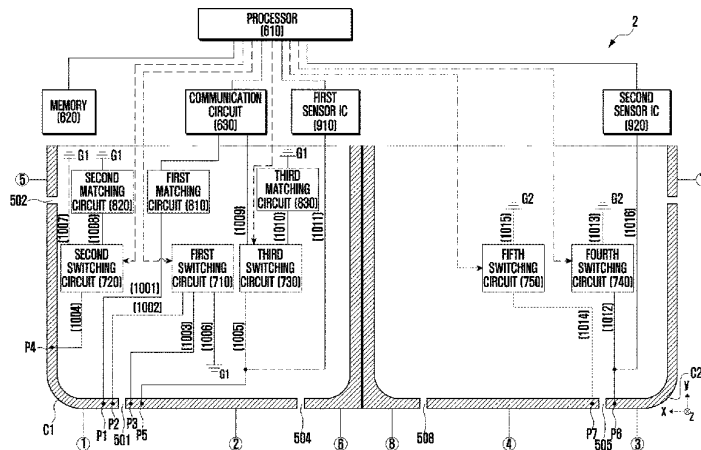



US012363623B2

(12) **United States Patent**  
**Kalkunte et al.**

(10) **Patent No.:** **US 12,363,623 B2**  
(45) **Date of Patent:** **\*Jul. 15, 2025**

(54) **EDGE DEVICE AND METHOD FOR HANDLING SERVICE FOR MULTIPLE SERVICE PROVIDERS**

(71) Applicant: **PELTBEAM INC.**, Sherman Oaks, CA (US)

(72) Inventors: **Venkat Kalkunte**, Saratoga, CA (US);  
**Mehdi Hatamian**, Mission Viejo, CA (US)

(73) Assignee: **PELTBEAM INC.**, Sherman Oaks, CA (US)

(\*) Notice: Subject to any disclaimer, the term of this patent is extended or adjusted under 35 U.S.C. 154(b) by 0 days.

This patent is subject to a terminal disclaimer.

(21) Appl. No.: **18/967,703**

(22) Filed: **Dec. 4, 2024**

(65) **Prior Publication Data**

US 2025/0097832 A1 Mar. 20, 2025

**Related U.S. Application Data**

(63) Continuation of application No. 17/661,037, filed on Apr. 27, 2022, which is a continuation of application No. 17/453,141, filed on Nov. 1, 2021, now Pat. No. 11,356,936, which is a continuation of application (Continued)

(51) **Int. Cl.**  
**H04W 48/16** (2009.01)  
**H04L 67/1001** (2022.01)  
**H04W 48/18** (2009.01)  
**H04W 64/00** (2009.01)  
**H04W 72/0453** (2023.01)  
**H04W 76/10** (2018.01)

(52) **U.S. Cl.**  
CPC ..... **H04W 48/16** (2013.01); **H04W 48/18** (2013.01); **H04W 64/003** (2013.01); **H04W 72/0453** (2013.01); **H04W 76/10** (2018.02); **H04L 67/1001** (2022.05)

(58) **Field of Classification Search**  
None  
See application file for complete search history.

(56) **References Cited**  
U.S. PATENT DOCUMENTS

2020/0322812 A1\* 10/2020 Shi ..... H04W 16/28  
2020/0403689 A1\* 12/2020 Rofougaran ..... H04W 52/245  
2022/0116791 A1\* 4/2022 Lin ..... H04B 7/0695

\* cited by examiner

*Primary Examiner* — Kodzovi Acolatse  
*Assistant Examiner* — Anindita Sen  
(74) *Attorney, Agent, or Firm* — CHIP LAW GROUP

(57) **ABSTRACT**

An edge device that includes first antenna arrays at donor side and second antenna arrays at service side of the edge device, and a processor that obtains wireless connectivity enhanced information from a central cloud server based on a position of the edge device, where the wireless connectivity enhanced information is provided for a first user equipment (UE) and a second UE, and includes selected initial access information to accelerate a UE-specific beam alignment for each of the first UE and the second UE and connectivity to a corresponding base station from the edge device bypassing an initial access-search on the edge device. The processor receives a first donor beam associated with a first wireless carrier network (WCN) from a first base station, and receives a second donor beam associated with a second WCN from a second base station via the one or more first antenna arrays.

**18 Claims, 8 Drawing Sheets**

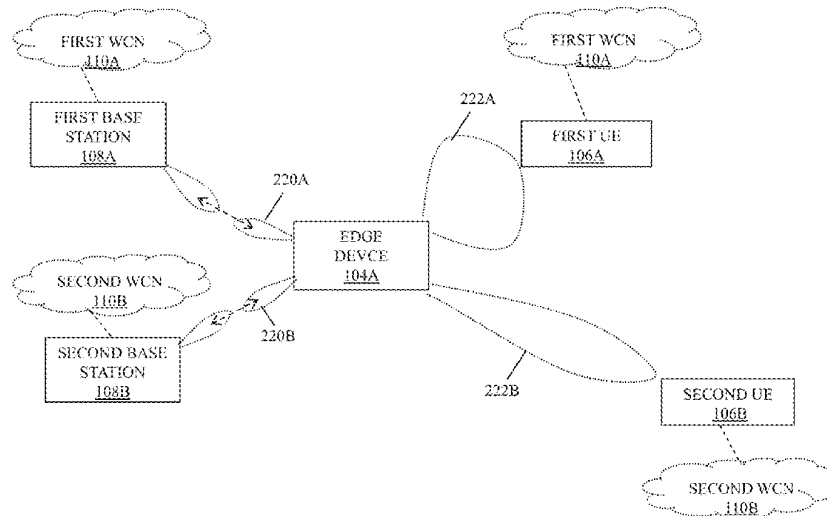



US012363741B2

(12) **United States Patent**  
**Huber et al.**

(10) **Patent No.:** **US 12,363,741 B2**  
(45) **Date of Patent:** **Jul. 15, 2025**

(54) **ALLOCATING RADIO RESOURCES TO IDLE USER EQUIPMENT THAT WAS PREDICTED TO TRANSITION TO ACTIVE MODE**

(52) **U.S. Cl.**  
CPC ..... *H04W 72/51* (2023.01); *H04W 72/046* (2013.01); *H04W 72/56* (2023.01); *H04W 24/02* (2013.01)

(71) Applicants: **AT&T INTELLECTUAL PROPERTY I, L.P.**, Atlanta, GA (US); **AT&T INTELLECTUAL PROPERTY II, L.P.**, Atlanta, GA (US); **AT&T TECHNICAL SERVICES COMPANY, INC.**, Vienna, VA (US); **AT&T Mobility II LLC**, Atlanta, GA (US)

(58) **Field of Classification Search**  
CPC ... H04W 72/51; H04W 72/56; H04W 72/046; H04W 24/02  
See application file for complete search history.

(72) Inventors: **Kurt Huber**, Ashburn, VA (US); **Thomas Henderson**, Alpharetta, GA (US); **Daniel Vivanco**, Ashburn, VA (US); **Julius Fodje**, Alpharetta, GA (US)

(56) **References Cited**  
U.S. PATENT DOCUMENTS  
2016/0150475 A1 \* 5/2016 Rune ..... H04W 52/0216 370/311  
2019/0357298 A1 \* 11/2019 Li ..... H04W 24/02  
2023/0247655 A1 \* 8/2023 Ly ..... H04W 72/1268 370/329

(73) Assignees: **AT&T Intellectual Property I, L.P.**, Atlanta, GA (US); **AT&T Intellectual Property II, L.P.**, Atlanta, GA (US); **AT&T Technical Services Company, Inc.**, Vienna, VA (US); **AT&T Mobility II LLC**, Atlanta, GA (US)

\* cited by examiner  
*Primary Examiner* — Kevin C. Harper  
*Assistant Examiner* — Salma Ayad

(\* ) Notice: Subject to any disclaimer, the term of this patent is extended or adjusted under 35 U.S.C. 154(b) by 489 days.

(57) **ABSTRACT**  
The technologies described herein are generally directed to providing radio resources to facilitate a predicted transition to active mode by idle user equipment in a fifth generation (5G) network or other next generation networks. An example method can include predicting that a user equipment of a group of user equipment in an idle mode will transition to an active mode after passage of a time duration, starting from the predicting, that is lower than a time threshold. The method can further include identifying base station equipment that is able to provide coverage to the user equipment during the passage of the time duration before the user equipment transitions to the active mode. Further, the method can include prioritizing allocation of, within the group of user equipment, an antenna resource of the base station equipment to provide the coverage to facilitate an active mode connection by the user equipment to the base station equipment.

(21) Appl. No.: **17/829,051**

(22) Filed: **May 31, 2022**

(65) **Prior Publication Data**  
US 2023/0389116 A1 Nov. 30, 2023

(51) **Int. Cl.**  
*H04W 72/51* (2023.01)  
*H04W 24/02* (2009.01)

(Continued)

**20 Claims, 10 Drawing Sheets**

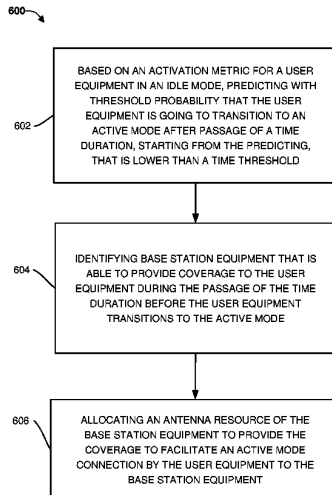



US012334632B2

(12) **United States Patent**  
**Qin et al.**

(10) **Patent No.:** **US 12,334,632 B2**  
(45) **Date of Patent:** **Jun. 17, 2025**

(54) **ANTENNA ASSEMBLY AND COMMUNICATION SYSTEM**

(71) Applicant: **ANHUI ANUKI TECHNOLOGIES CO., LTD.**, Anhui (CN)

(72) Inventors: **Kun Qin**, Anhui (CN); **Jian Niu**, Anhui (CN); **Chengjie Zuo**, Anhui (CN); **Jun He**, Anhui (CN)

(73) Assignee: **ANHUI ANUKI TECHNOLOGIES CO., LTD.**, Anhui (CN)

(\* ) Notice: Subject to any disclaimer, the term of this patent is extended or adjusted under 35 U.S.C. 154(b) by 0 days.

(21) Appl. No.: **18/027,238**

(22) PCT Filed: **Aug. 5, 2022**

(86) PCT No.: **PCT/CN2022/110650**

§ 371 (c)(1),

(2) Date: **Mar. 20, 2023**

(87) PCT Pub. No.: **WO2023/138034**

PCT Pub. Date: **Jul. 27, 2023**

(65) **Prior Publication Data**

US 2024/0291141 A1 Aug. 29, 2024

(30) **Foreign Application Priority Data**

Jan. 18, 2022 (CN) ..... 202210056152.8

(51) **Int. Cl.**

**H01Q 1/50** (2006.01)

**H01Q 1/36** (2006.01)

(52) **U.S. Cl.**

CPC ..... **H01Q 1/50** (2013.01); **H01Q 1/362** (2013.01)

(58) **Field of Classification Search**

CPC ..... H01Q 1/50; H01Q 1/362; H01Q 23/00; H01Q 5/335; H01Q 15/0006

See application file for complete search history.

(56) **References Cited**

U.S. PATENT DOCUMENTS

6,784,762 B2\* 8/2004 Kato ..... H03H 7/1775  
333/204

10,171,063 B2\* 1/2019 Lee ..... H01Q 5/50

(Continued)

FOREIGN PATENT DOCUMENTS

CN 1433105 A 7/2003

CN 205723920 U 11/2016

(Continued)

OTHER PUBLICATIONS

International Search Report and Written Opinion issued in related PCT Application No. PCT/CN2022/110650, on Sep. 30, 2022, in 10 pages.

(Continued)

*Primary Examiner* — Seung H Lee

(74) *Attorney, Agent, or Firm* — Davis Wright Tremaine LLP

(57) **ABSTRACT**

Provided are an antenna assembly and a communication system, relating to the technical field of antennas. The antenna assembly comprises a filter module and an antenna module, wherein the antenna module is connected to the filter module, and the antenna module is integrated with the filter module, wherein an output impedance of the filter module is matched with an input impedance of the antenna module.

**19 Claims, 2 Drawing Sheets**

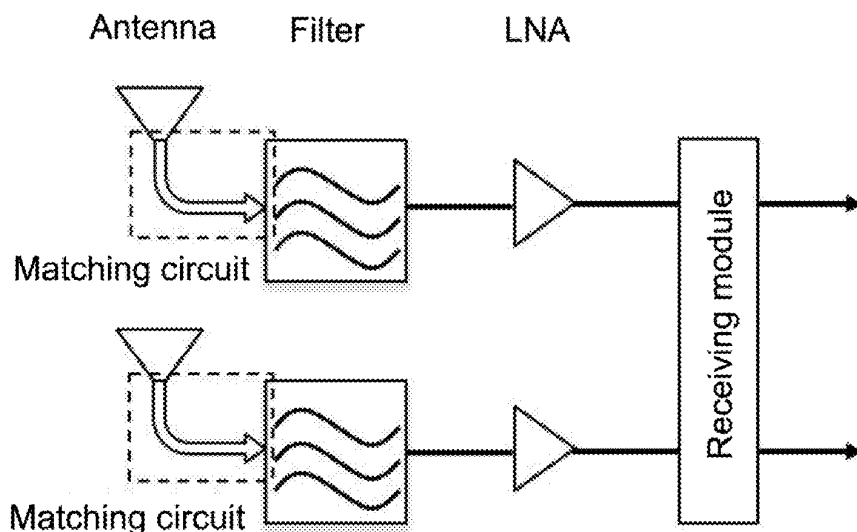



US012334878B2

(12) **United States Patent**  
**Yang et al.**

(10) **Patent No.:** **US 12,334,878 B2**  
(45) **Date of Patent:** **Jun. 17, 2025**

(54) **ELECTRONIC DEVICE AND METHOD INCLUDING POWER AMPLIFIER MODULE HAVING PROTECTION CIRCUIT**

(58) **Field of Classification Search**  
CPC ..... H04B 1/0458; H04B 1/04; H04B 2001/0408; H04B 2001/0416; H03F 1/52; H03F 1/56; H03F 3/245  
See application file for complete search history.

(71) Applicant: **SAMSUNG ELECTRONICS CO., LTD.**, Suwon-si (KR)

(56) **References Cited**

(72) Inventors: **Jaemin Yang**, Suwon-si (KR); **Hyoseok Na**, Suwon-si (KR)

U.S. PATENT DOCUMENTS

(73) Assignee: **SAMSUNG ELECTRONICS CO., LTD.**, Suwon-si (KR)

7,480,345 B2 \* 1/2009 Kurakami ..... H03F 3/45085 375/297  
8,076,974 B2 12/2011 Tanaka et al.  
(Continued)

(\* ) Notice: Subject to any disclaimer, the term of this patent is extended or adjusted under 35 U.S.C. 154(b) by 429 days.

FOREIGN PATENT DOCUMENTS

(21) Appl. No.: **17/969,302**

EP 3379724 9/2018  
JP 2009-284034 12/2009  
(Continued)

(22) Filed: **Oct. 19, 2022**

OTHER PUBLICATIONS

(65) **Prior Publication Data**

US 2023/0163730 A1 May 25, 2023

Search Report and Written Opinion dated Dec. 21, 2022 issued in International Patent Application No. PCT/KR2022/013484.

*Primary Examiner* — Tuan Pham

(74) *Attorney, Agent, or Firm* — Nixon & Vanderhye, P.C.

**Related U.S. Application Data**

(63) Continuation of application No. PCT/KR2022/013484, filed on Sep. 7, 2022.

(57) **ABSTRACT**

(30) **Foreign Application Priority Data**

Nov. 22, 2021 (KR) ..... 10-2021-0161796

An electronic device includes: an antenna, a PAM including a PA configured to amplify a transmitting signal and a protection circuit, a PMIC configured to supply voltage to the PA, and at least one processor is configured to: provide a first signal, to a NAND gate in the protection circuit, provide to a AND gate in the protection circuit, a second signal indicating a result of a logical operation between the first signal and a bias enable signal for the PA, provide to the AND gate, a third signal indicating whether the transmitting signal is input to the PAM, provide to a switching circuit, a fourth signal indicating a result of logical operation between the second signal and the third signal, identify whether to apply a bias voltage to the PA based on the fourth signal, and

(Continued)

(51) **Int. Cl.**  
**H04B 1/04** (2006.01)  
**H03F 1/52** (2006.01)  
(Continued)

(52) **U.S. Cl.**  
CPC ..... **H03F 1/52** (2013.01); **H03F 1/56** (2013.01); **H03F 3/245** (2013.01); **H04B 1/0458** (2013.01);  
(Continued)

